

Applications:	
Honda Accord	2008-2012
Honda Pilot	2009-2012
Honda Ridgeline	2009-2012
Acura RL	2009-2010

28600-R97-003  
2nd Clutch Pressure  
Switch

**Mode 1**

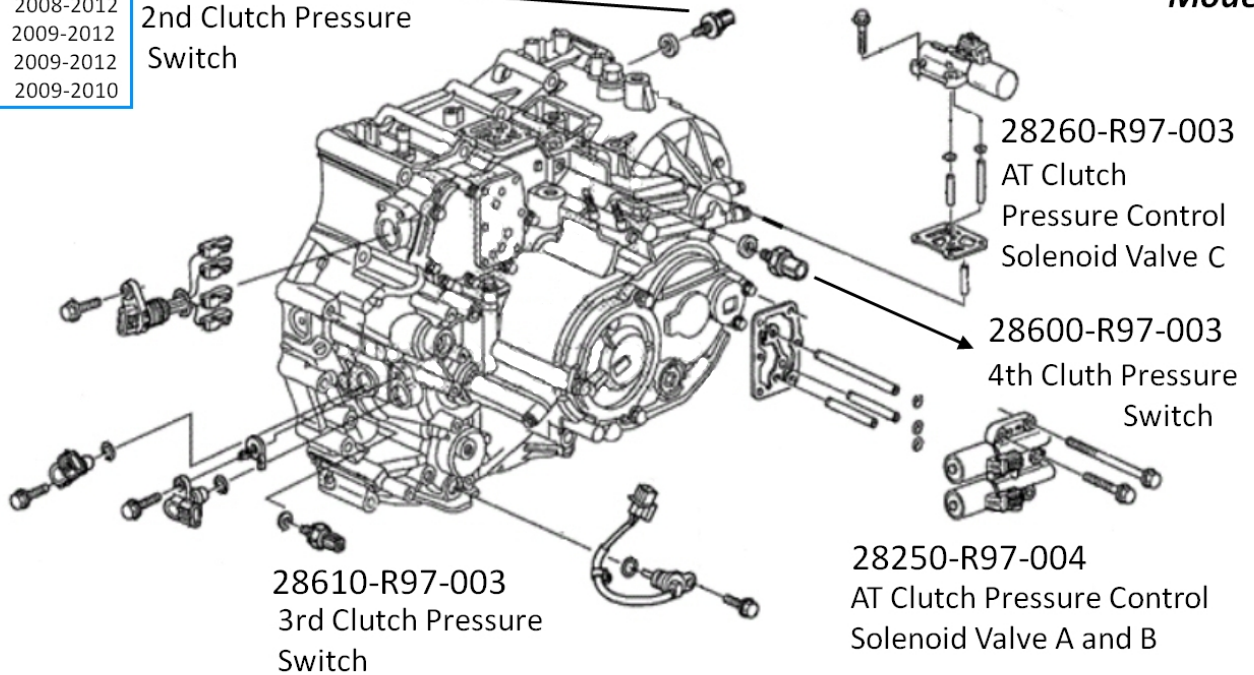

## AT Clutch Pressure Control Solenoid Valve C Test

1. Connect the HDS to the DLC (A) located under the driver's side of the dashboard.

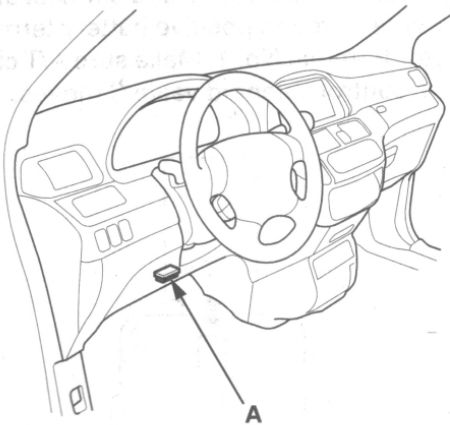

6. Disconnect the A/T clutch pressure control solenoid valve C connector.

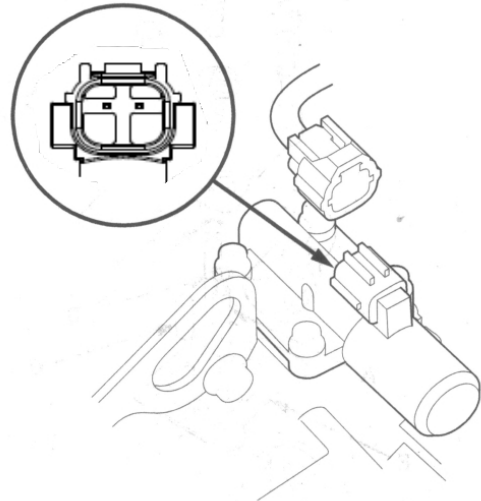

2. Turn the ignition switch to ON (II). Make sure the HDS communicates with the PCM. If it does not, go to the DLC circuit troubleshooting (see page 11-269).

3. Select Clutch Pressure Control (Linear) Solenoid Valve C in the Miscellaneous Test Menu on the HDS.

4. Test A/T clutch pressure control solenoid valve C with the HDS.

- If the valve tests OK, the test is complete. Disconnect the HDS.
- If the valve does not test OK, follow the instructions on the HDS.
- If the valve does not test OK, and the HDS does not determine the cause, go to step 5.

5. Remove the engine cover and the air cleaner assembly.

7. Measure the A/T clutch pressure control solenoid valve C resistance at the connector terminals.

**Standard: 3–10 Ω**

- If the resistance is out of the standard, replace A/T clutch pressure control solenoid valve C (see page 14-194).
- If the resistance is within the standard, go to step 8.

8. Connect a jumper wire from the negative battery terminal to solenoid valve C connector terminal No. 2, and connect another jumper wire from the positive battery terminal to the connector terminal No. 1.

- If a clicking sound is heard, the valve is OK, and the test is complete, then go to step 20.
- If no clicking sound is heard, go to step 9.

9. Remove A/T clutch pressure control solenoid valve C.

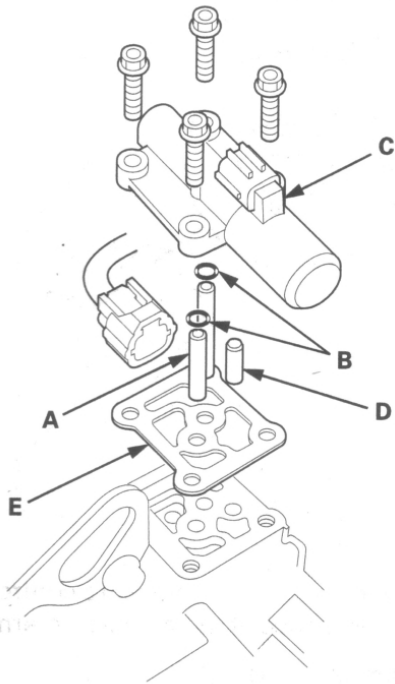

10. Remove the ATF joint pipes (A), the O-rings (B), the ATF pipe (D), and the gasket (E).

11. Check the fluid passage of the solenoid valve for contamination.

12. Connect a jumper wire from the negative battery terminal to A/T clutch pressure control solenoid valve C connector terminal No. 2, and connect another jumper wire from the positive battery terminal to the connector terminal No. 1. Make sure A/T clutch pressure control solenoid valve C moves.

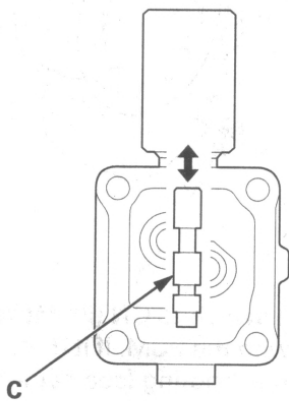

13. Disconnect one of the battery terminals and check the valve movement at the fluid passage in valve body mounting surface. If the valve binds or moves sluggishly, or if the solenoid valve does not operate, replace A/T clutch pressure control solenoid valve C.

14. Clean the mounting surfaces and the fluid passages of the solenoid valve body and the transmission housing.

15. Install the 8 x 53 mm ATF joint pipe (A) with the filter end into its mounting hole (B).

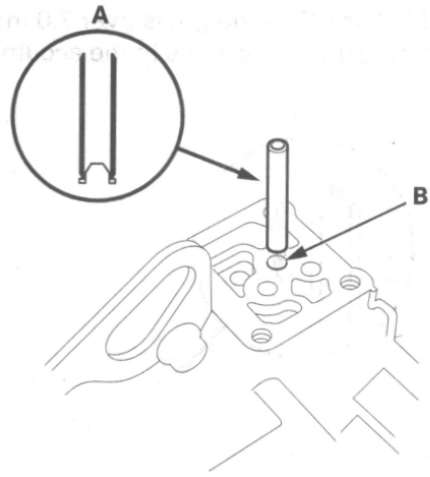

16. Check the height (A) of the 8 x 53 mm ATF joint pipe (B) between the top (C) of the pipe and the solenoid valve body mounting surface (D). The height is about 7.0 mm (0.28 in). If the height is over 7.0 mm (0.28 in), push the pipe until it bottoms in the accumulator body.

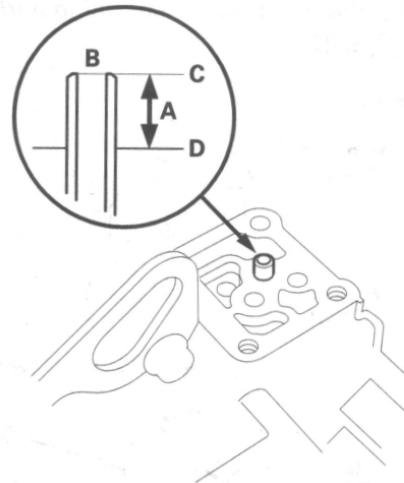

17. Install a new gasket (A) on the transmission housing, and install the 8 x 36 mm ATF joint pipe (B) with the filter end in the transmission housing and the 8 x 25.2 mm ATF pipe (D).

6 x 1.0 mm  
12 N·m  
(1.2 kgf·m, 8.7 lbf·ft)

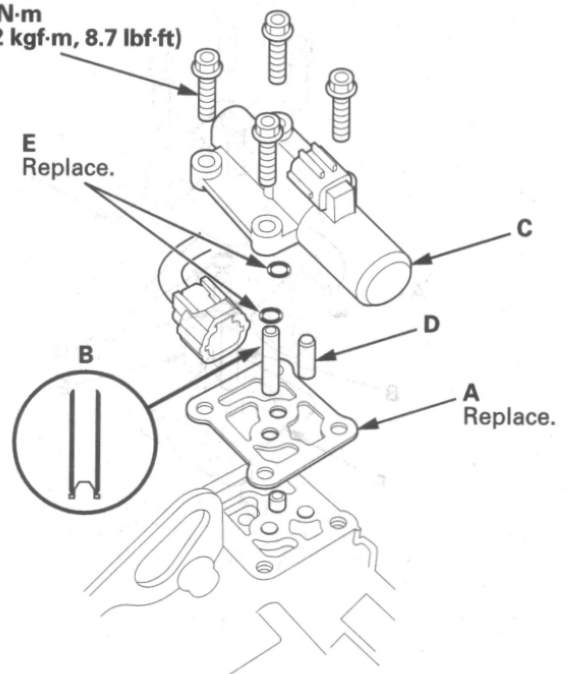

18. Install new O-rings (E) over the ATF joint pipes.
19. Install A/T clutch pressure control solenoid valve C.
20. Check the connector for rust, dirt, or oil, and clean or repair if necessary, then connect the connector securely.
21. Install the air cleaner assembly and the engine cover.

## A/T Clutch Pressure Control Solenoid Valve C Replacement

1. Remove the engine cover and the air cleaner assembly.
2. Disconnect the A/T clutch pressure control solenoid valve C connector (A).

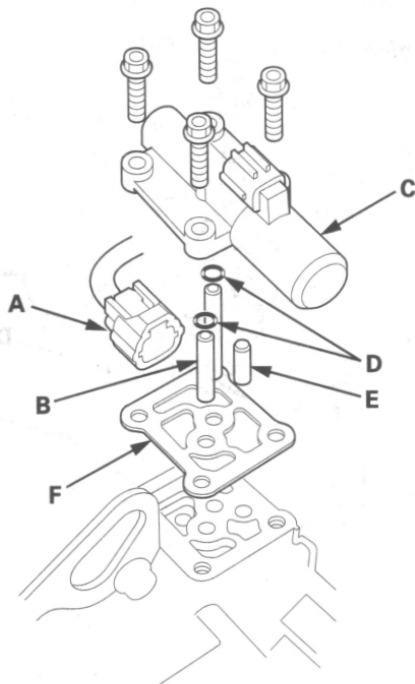

3. Remove A/T clutch pressure control solenoid valve C.
4. Remove the ATF joint pipes (B), the O-rings (D), the ATF pipe (E), and the gasket (F).
5. Clean the mounting surfaces and the fluid passages of the transmission housing.
6. Install the 8 x 53 mm ATF joint pipe (A) with the filter end into its mounting hole (B).

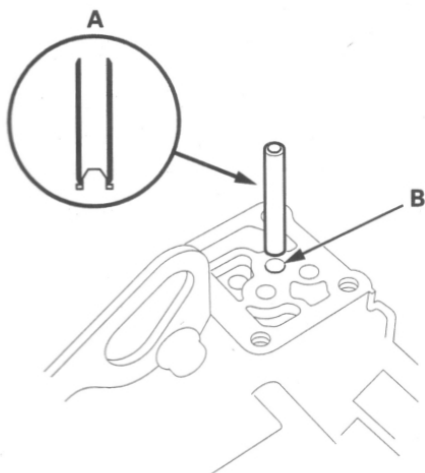

7. Check the height (A) of the 8 x 53 mm ATF joint pipe (B) between the top (C) of the pipe and the solenoid valve body mounting surface (D). The height is about 7.0 mm (0.28 in). If the height is over 7.0 mm (0.28 in), push the pipe until it bottoms in the accumulator body.

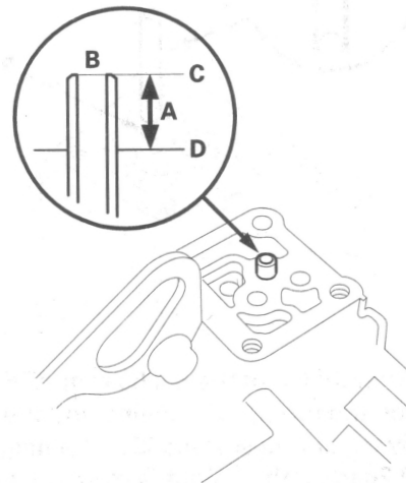

8. Install a new gasket (A) on the transmission housing, and install the 8 x 36 mm ATF joint pipe (B) with the filter end in the transmission housing and the 8 x 25.2 mm ATF pipe (D).

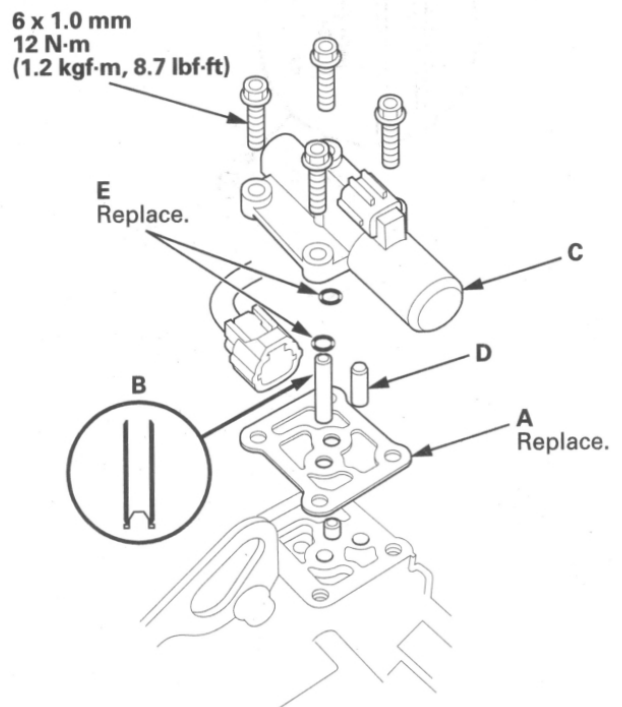

9. Install new O-rings (E) over the ATF joint pipes.
10. Install A/T clutch pressure control solenoid valve C.
11. Check the connector for rust, dirt, or oil, and clean or repair if necessary, then connect the connector securely.
12. Install the air cleaner assembly and the engine cover.

# DTC Troubleshooting

## DTC P0796: A/T Clutch Pressure Control Solenoid Valve C Stuck OFF

NOTE: Before you troubleshoot, record all freeze data and any on-board snapshot with the HDS, and review General Troubleshooting Information (see page 14-4).

1. Warm up the engine to normal operating temperature (the radiator fan comes on).
2. Make sure that the transmission is filled to the proper level, and check for fluid leaks.
3. Drain the ATF (see step 3 on page 14-201) through a strainer. Inspect the strainer for metal debris or excessive clutch material.

*Does the strainer have metal debris or excessive clutch material?*

**YES**—Replace the transmission, then go to step 13.

**NO**—Replace the ATF (see step 5 on page 14-201), then go to step 4.

4. Turn the ignition switch to ON (II).
5. Clear the DTC with the HDS.
6. Start the engine with the shift lever in P. Press the brake pedal and shift to 1. Then test-drive the vehicle with the shift lever in R.
7. Monitor the OBD STATUS for P0796 in the DTCs MENU with the HDS.

*Does the HDS indicate FAILED?*

**YES**—Go to step 8.

**NO**—If the HDS indicates PASSED, intermittent failure, the system is OK at this time. If the HDS indicates NOT COMPLETED, go to step 6.

8. Clear the DTC with the HDS.
9. Select Clutch Pressure Control (Linear) Solenoid Valve C in the Miscellaneous Test Menu, and test A/T clutch pressure control solenoid valve C with the HDS.

*Does the HDS indicate NORMAL?*

**YES**—Intermittent failure, the system is OK at this time.■

**NO**—Follow the instructions indicated on the HDS according to the test result. If the HDS has not determined the cause of the failure, go to step 10. If any part was replaced, go to step 11.

10. Inspect A/T clutch pressure control solenoid valve C (see page 14-191).

*Does A/T clutch pressure control solenoid valve C work properly?*

**YES**—Repair the hydraulic system related to the reverse CPC valve, the lock-up shift valve, and CPC valve C, or replace the transmission, then go to step 13.

**NO**—Replace A/T clutch pressure control solenoid valve C (see page 14-194), then go to step 11.

11. Turn the ignition switch to ON (II).
12. Clear the DTC with the HDS.
13. Start the engine with the shift lever in P. Test-drive the vehicle in D, and let the transmission shift through all five gears. Then run the vehicle with the shift lever in R.
14. Check for Pending or Confirmed DTCs with the HDS.

*Is DTC P0796 indicated?*

**YES**—Go to step 8.

**NO**—Go to step 15.

15. Monitor the OBD STATUS for P0796 in the DTCs MENU with the HDS.

*Does the HDS indicate PASSED?*

**YES**—Troubleshooting is complete. If any other Pending or Confirmed DTCs were indicated in step 14, go to the indicated DTC's troubleshooting.■

**NO**—If the HDS indicates FAILED, go to step 8. If the HDS indicates NOT COMPLETED, go to step 13.

## DTC P0797: A/T Clutch Pressure Control Solenoid Valve C Stuck ON

NOTE: Before you troubleshoot, record all freeze data and any on-board snapshot with the HDS, and review General Troubleshooting Information (see page 14-4).

1. Warm up the engine to normal operating temperature (the radiator fan comes on).
2. Make sure that the transmission is filled to the proper level, and check for fluid leaks.
3. Drain the ATF (see step 3 on page 14-201) through a strainer. Inspect the strainer for metal debris or excessive clutch material.

*Does the strainer have metal debris or excessive clutch material?*

**YES**—Replace the transmission, then go to step 13.

**NO**—Replace the ATF (see step 5 on page 14-201), then go to step 4.

4. Turn the ignition switch to ON (II).
5. Clear the DTC with the HDS.
6. Test-drive the vehicle with the shift lever in D, and let the transmission shift through all five gears.
7. Monitor the OBD STATUS for P0797 in the DTCs MENU with the HDS.

*Does the HDS indicate FAILED?*

**YES**—Go to step 8.

**NO**—If the HDS indicates PASSED, intermittent failure, the system is OK at this time. If the HDS indicates NOT COMPLETED, go to step 6.

8. Clear the DTC with the HDS.

9. Select Clutch Pressure Control (Linear) Solenoid Valve C in the Miscellaneous Test Menu, and test A/T clutch pressure control solenoid valve C with the HDS.

*Does the HDS indicate NORMAL?*

**YES**—Intermittent failure, the system is OK at this time. ■

**NO**—Follow the instructions indicated on the HDS according to the test result. If the HDS has not determined the cause of the failure, go to step 10. If any part was replaced, go to step 11.

10. Inspect A/T clutch pressure control solenoid valve C (see page 14-191).

*Does A/T clutch pressure control solenoid valve C work properly?*

**YES**—Repair the hydraulic system related to the reverse CPC valve, the lock-up shift valve, and CPC valve C, or replace the transmission, then go to step 13.

**NO**—Replace A/T clutch pressure control solenoid valve C (see page 14-194), then go to step 11.

11. Turn the ignition switch to ON (II).

12. Clear the DTC with the HDS.

13. Test-drive the vehicle with the shift lever in D, and let the transmission shift through all five gears.

14. Check for Pending or Confirmed DTCs with the HDS.

*Is DTC P0797 indicated?*

**YES**—Go to step 8.

**NO**—Go to step 15.

15. Monitor the OBD STATUS for P0797 in the DTCs MENU with the HDS.

*Does the HDS indicate PASSED?*

**YES**—Troubleshooting is complete. If any other Pending or Confirmed DTCs were indicated in step 14, go to the indicated DTC's troubleshooting. ■

**NO**—If the HDS indicates FAILED, go to step 8. If the HDS indicates NOT COMPLETED, go to step 13.

### DTC P0970: Problem in A/T Clutch Pressure Control Solenoid Valve C Circuit

#### NOTE:

- Before you troubleshoot, record all freeze data and any on-board snapshot with the HDS, and review General Troubleshooting Information (see page 14-4).
- This code is caused by an electrical circuit problem and cannot be caused by a mechanical problem in the transmission.

1. Turn the ignition switch to ON (II).

2. Clear the DTC with the HDS.

3. Start the engine, and wait for at least 1 second.

4. Check for Pending or Confirmed DTCs with the HDS.

*Is DTC P0970 indicated?*

**YES**—Go to step 8.

**NO**—Go to step 5.

5. Select Clutch Pressure Control Solenoid Valve C in the Miscellaneous Test Menu, and test A/T clutch pressure control solenoid valve C with the HDS.

*Does the HDS indicate NORMAL?*

**YES**—Go to step 6.

**NO**—Go to step 8.

6. In the Clutch Pressure Control Solenoid Valve control menu, select A/T Clutch Pressure Control Solenoid Valve C at 1.0 A.

7. Monitor the OBD STATUS for P0970 in the DTCs MENU with the HDS.

*Does the HDS indicate FAILED?*

**YES**—Go to step 8.

**NO**—If the HDS indicates PASSED, intermittent failure, the system is OK at this time. Check for poor connections or loose terminals between A/T clutch pressure control solenoid valve C and the PCM. If the HDS indicates NOT COMPLETED, go to step 5.

8. Turn the ignition switch to LOCK (0).

9. Disconnect the A/T clutch pressure control solenoid valve C connector.

10. Measure the resistance between A/T clutch pressure control solenoid valve C connector terminals No. 1 and No. 2.

#### A/T CLUTCH PRESSURE CONTROL SOLENOID VALVE C CONNECTOR

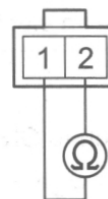

Terminal side of male terminals

*Is there 3–10 Ω?*

**YES**—Go to step 11.

**NO**—Replace A/T clutch pressure control solenoid valve C (see page 14-194), then go to step 18.

11. Check for continuity between A/T clutch pressure control solenoid valve C connector terminal No. 2 and body ground.

**A/T CLUTCH PRESSURE CONTROL SOLENOID VALVE C CONNECTOR**

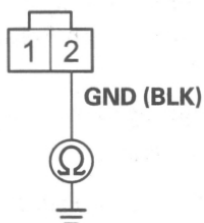

Wire side of female terminals

*Is there continuity?*

**YES**—Go to step 12.

**NO**—Repair open in the wire between A/T clutch pressure control solenoid valve C and body ground body ground (G101) (see page 22-23), or repair poor body ground (G101) (see page 22-23), then go to step 18.

12. Jump the SCS line with the HDS.

13. Disconnect PCM connector B (49P).

14. Check for continuity between A/T clutch pressure control solenoid valve C connector terminal No. 1 and body ground.

**A/T CLUTCH PRESSURE CONTROL SOLENOID VALVE C CONNECTOR**

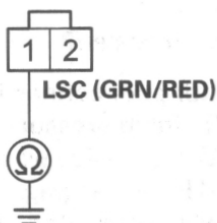

Wire side of female terminals

*Is there continuity?*

**YES**—Repair short to body ground in the wire between PCM connector terminal B21 and A/T clutch pressure control solenoid valve C, then go to step 18.

**NO**—Go to step 15.

15. Check for continuity between A/T clutch pressure control solenoid valve C connector terminal No. 1 and PCM connector terminal B21.

**PCM CONNECTOR B (49P)**

**A/T CLUTCH PRESSURE CONTROL SOLENOID VALVE C CONNECTOR**

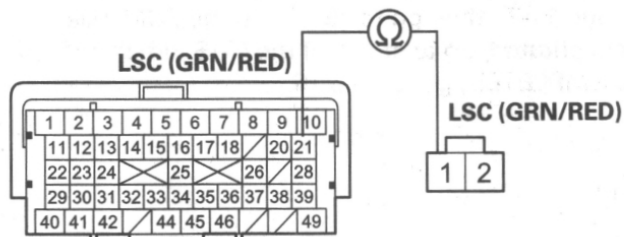

Terminal side of female terminals

Wire side of female terminals

*Is there continuity?*

**YES**—Go to step 16.

**NO**—Repair open in the wire between A/T clutch pressure control solenoid valve C connector terminal No. 1 and PCM connector terminal B21, then go to step 18.

16. Turn the ignition switch to ON (II).

17. Measure the voltage between PCM connector terminal B2 and body ground.

**PCM CONNECTOR B (49P)**

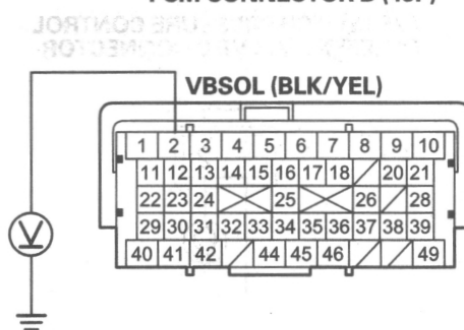

Terminal side of female terminals

*Is there battery voltage?*

**YES**—Go to step 24.

**NO**—Check for a blown No. 18 (15 A) fuse in the driver's under-dash fuse/relay box. If the fuse is OK, repair open in the wire between PCM connector terminal B2 and the driver's under-dash fuse/relay box, then go to step 18.

18. Reconnect all connectors.

19. Turn the ignition switch to ON (II).

20. Clear the DTC with the HDS.

21. Start the engine, and wait for at least 1 second.

22. Check for Pending or Confirmed DTCs with the HDS.

*Is DTC P0970 indicated?*

**YES**—Check for poor connections or loose terminals between A/T clutch pressure control solenoid valve C and the PCM, then go to step 1.

**NO**—Go to step 23.

23. Monitor the OBD STATUS for P0970 in the DTCs MENU with the HDS.

*Does the HDS indicate PASSED?*

**YES**—Troubleshooting is complete. If any other Pending or Confirmed DTCs were indicated in step 22, go to the indicated DTC's troubleshooting. ■

**NO**—If the HDS indicates FAILED, check for poor connections or loose terminals between A/T clutch pressure control solenoid valve C and the PCM, then go to step 1. If the HDS indicates NOT COMPLETED, go to step 21.

24. Reconnect all connectors.

25. Update the PCM if it does not have the latest software (see page 11-292), or substitute a known-good PCM (see page 11-7).

26. Start the engine, and wait for at least 1 second.

27. Check for Pending or Confirmed DTCs with the HDS.

*Is DTC P0970 indicated?*

**YES**—Check for poor connections or loose terminals between A/T clutch pressure control solenoid valve C and the PCM. If the PCM was updated, substitute a known-good PCM (see page 11-7), then go to step 26. If the PCM was substituted, go to step 1.

**NO**—Go to step 28.

28. Monitor the OBD STATUS for P0970 in the DTCs MENU with the HDS.

*Does the HDS indicate PASSED?*

**YES**—If the PCM was updated, troubleshooting is complete. If the PCM was substituted, replace the original PCM (see page 11-294). If any other Pending or Confirmed DTCs were indicated in step 27, go to the indicated DTC's troubleshooting. ■

**NO**—If the HDS indicates FAILED, check for poor connections or loose terminals between A/T clutch pressure control solenoid valve C and the PCM. If the PCM was updated, substitute a known-good PCM (see page 11-7), then go to step 26. If the PCM was substituted, go to step 1. If the HDS indicates NOT COMPLETED, go to step 26.

### DTC P0971: Problem in A/T Clutch Pressure Control Solenoid Valve C

#### NOTE:

- Before you troubleshoot, record all freeze data and any on-board snapshot with the HDS, and review General Troubleshooting Information (see page 14-4).
- This code is caused by an electrical circuit problem and cannot be caused by a mechanical problem in the transmission.

1. Turn the ignition switch to ON (II).

2. Clear the DTC with the HDS.

3. Start the engine, and wait for at least 1 second.

4. Check for Pending or Confirmed DTCs with the HDS.

*Is DTC P0971 indicated?*

**YES**—Go to step 8.

**NO**—Go to step 5.

5. Select Clutch Pressure Control Solenoid Valve C in the Miscellaneous Test Menu, and test A/T clutch pressure control solenoid valve C with the HDS.

*Does the HDS indicate NORMAL?*

**YES**—Go to step 6.

**NO**—Go to step 8.

6. In the Clutch Pressure Control Solenoid Valve control menu, select A/T Clutch Pressure Control Solenoid Valve C at 0.2 A.

7. Monitor the OBD STATUS for P0971 in the DTCs MENU with the HDS.

*Does the HDS indicate FAILED?*

**YES**—Go to step 8.

**NO**—If the HDS indicates PASSED, intermittent failure, the system is OK at this time. Check for poor connections or loose terminals between A/T clutch pressure control solenoid valve C and the PCM. If the HDS indicates NOT COMPLETED, go to step 5.

8. Turn the ignition switch to LOCK (0).

9. Disconnect the A/T clutch pressure control solenoid valve C connector.

10. Measure the resistance between A/T clutch pressure control solenoid valve C connector terminals No. 1 and No. 2.

#### A/T CLUTCH PRESSURE CONTROL SOLENOID VALVE C CONNECTOR



Terminal side of male terminals

*Is there 3—10  $\Omega$ ?*

**YES**—Go to step 17.

**NO**—Replace A/T clutch pressure control solenoid valve C (see page 14-194), then go to step 11.

11. Reconnect all connectors.

12. Turn the ignition switch to ON (II).

13. Clear the DTC with the HDS.

14. Start the engine, and wait for at least 1 second.

15. Check for Pending or Confirmed DTCs with the HDS.

*Is DTC P0971 indicated?*

**YES**—Check for poor connections or loose terminals between A/T clutch pressure control solenoid valve C and the PCM, then go to step 1.

**NO**—Go to step 16.

16. Monitor the OBD STATUS for P0971 in the DTCs MENU with the HDS.

*Does the HDS indicate PASSED?*

**YES**—Troubleshooting is complete. If any other Pending or Confirmed DTCs were indicated in step 15, go to the indicated DTC's troubleshooting. ■

**NO**—If the HDS indicates FAILED, check for poor connections or loose terminals between A/T clutch pressure control solenoid valve C and the PCM, then go to step 1. If the HDS indicates NOT COMPLETED, go to step 14.

17. Reconnect all connectors.

18. Update the PCM if it does not have the latest software (see page 11-292), or substitute a known-good PCM (see page 11-7).

19. Start the engine, and wait for at least 1 second.

20. Check for Pending or Confirmed DTCs with the HDS.

*Is DTC P0971 indicated?*

**YES**—Check for poor connections or loose terminals between A/T clutch pressure control solenoid valve C and the PCM. If the PCM was updated, substitute a known-good PCM (see page 11-7), then go to step 19. If the PCM was substituted, go to step 1.

**NO**—Go to step 21.

21. Monitor the OBD STATUS for P0971 in the DTCs MENU with the HDS.

*Does the HDS indicate PASSED?*

**YES**—If the PCM was updated, troubleshooting is complete. If the PCM was substituted, replace the original PCM (see page 11-294). If any other Pending or Confirmed DTCs were indicated in step 20, go to the indicated DTC's troubleshooting. ■

**NO**—If the HDS indicates FAILED, check for poor connections or loose terminals between A/T clutch pressure control solenoid valve C and the PCM. If the PCM was updated, substitute a known-good PCM (see page 11-7), then go to step 19. If the PCM was substituted, go to step 1. If the HDS indicates NOT COMPLETED, go to step 19.

**Mode 2**

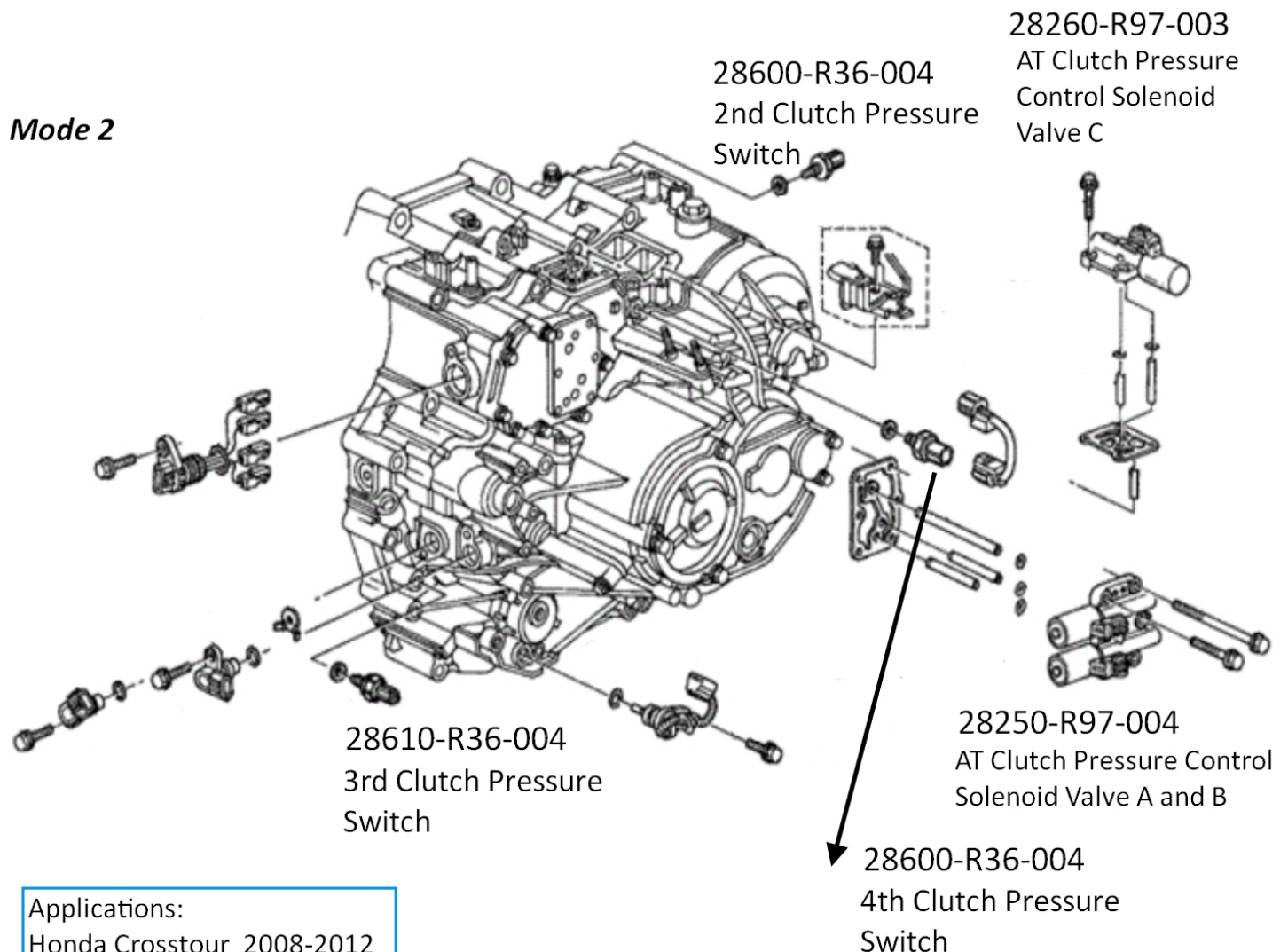

**Applications:**

- Honda Crosstour 2008-2012
- Honda Odyssey 2008-2013
- Acura TL 2009-2011



**Mode 3**

