

28600-R97-003  
2nd Clutch Pressure  
Switch

**Mode 1**

28260-R97-003  
AT Clutch  
Pressure Control  
Solenoid Valve C

28600-R97-003  
4th Clutch Pressure  
Switch

28610-R97-003  
3rd Clutch Pressure  
Switch

28250-R97-004  
AT Clutch Pressure Control  
Solenoid Valve A and B

## AT Clutch Pressure Control Solenoid Valve A and B Test

1. Connect the HDS to the DLC (A) located under the driver's side of the dashboard.

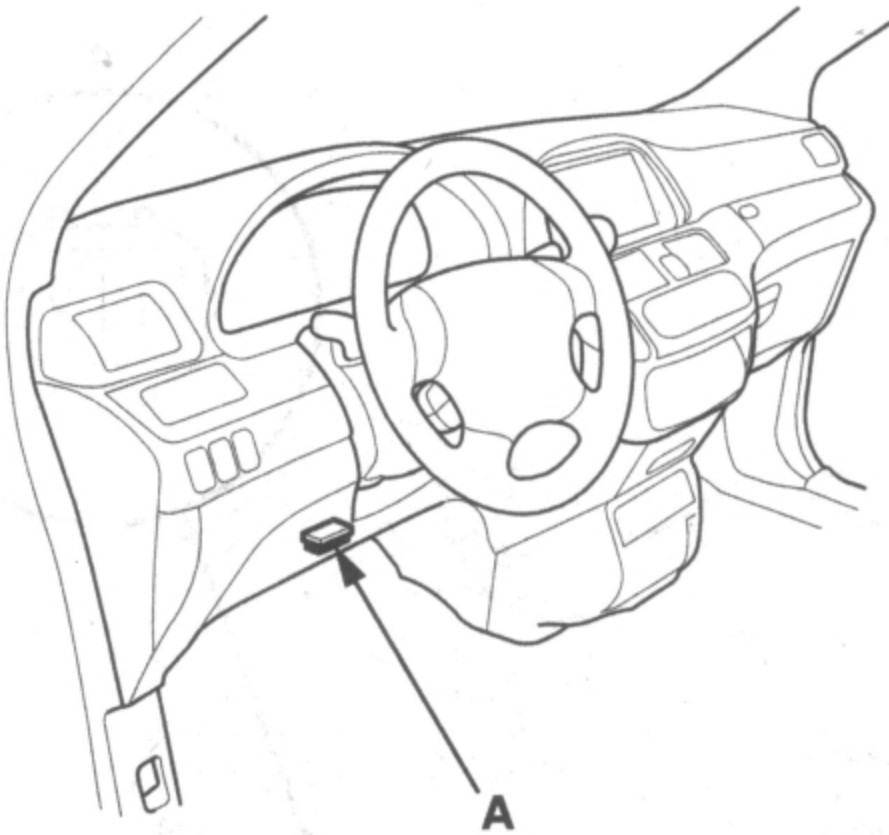

2. Turn the ignition switch to ON (II). Make sure the HDS communicates with the PCM. If it does not, go to the DLC circuit troubleshooting (see page 11-269).

3. Select Clutch Pressure Control (Linear) Solenoid Valve A or B in the Miscellaneous Test Menu on the HDS.

4. Test A/T clutch pressure control solenoid valve A or B with the HDS.

- If the valve tests OK, the test is complete. Disconnect the HDS.
- If the valve does not test OK, follow the instructions on the HDS.
- If the valve does not test OK, and the HDS does not determine the cause, go to step 5.

5. Do the battery removal procedure (see page 22-113).

6. Remove the engine cover and the air cleaner assembly.

7. Remove the battery base.

8. Disconnect the A/T clutch pressure control solenoid valve A and B connectors.

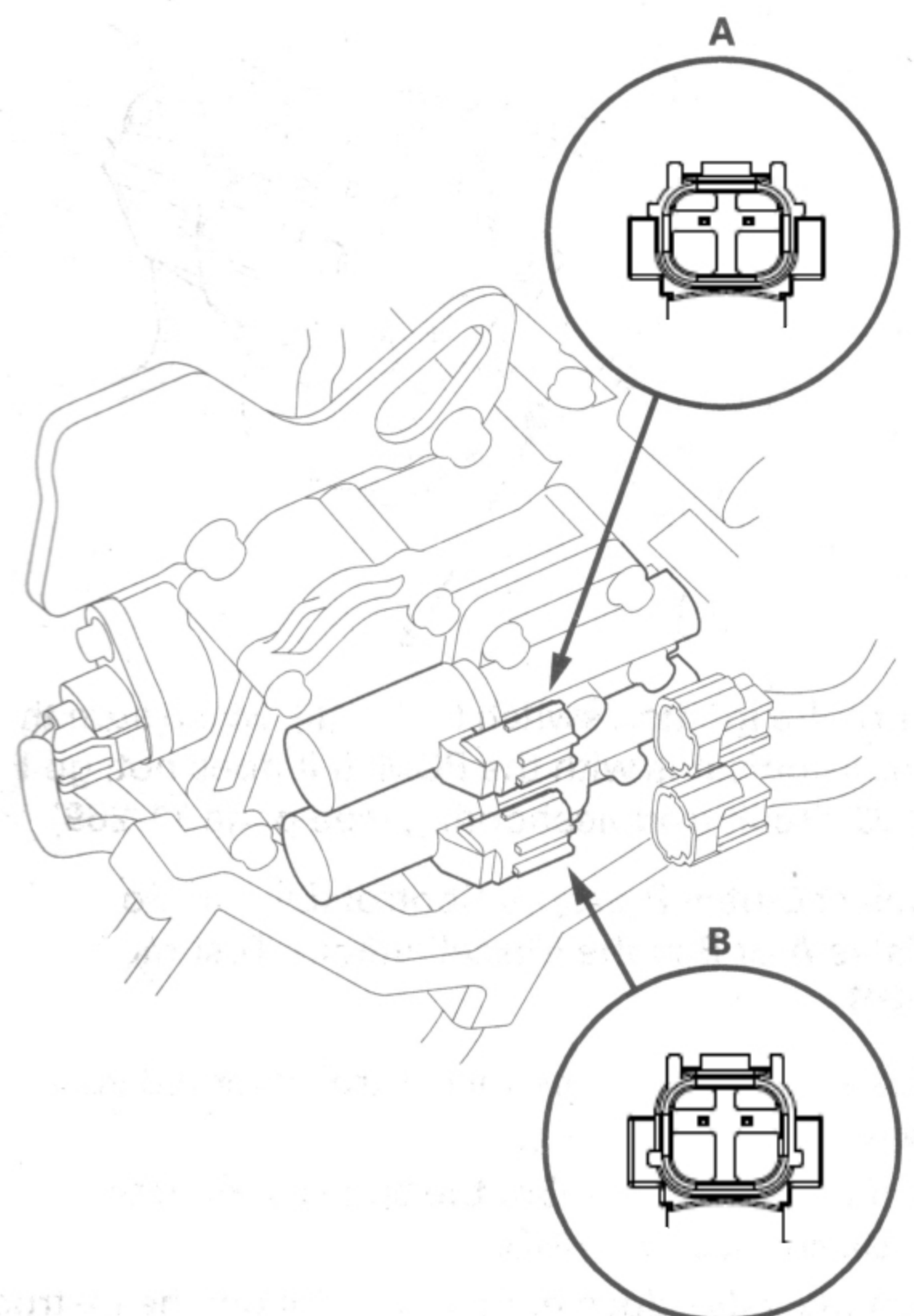



9. Measure the A/T clutch pressure control solenoid valve A or B resistance at the connector terminals.

**Standard: 3–10 Ω**

- If the resistance is out of the standard, replace A/T clutch pressure control solenoid valves A and B (see page 14-189).
- If the resistance is within the standard, go to step 10.

10. Connect a jumper wire from the negative battery terminal to solenoid valve A or B connector terminal No. 2, and connect another jumper wire from the positive battery terminal to the connector terminal No. 1.

- If a clicking sound is heard, the valve is OK, and the test is complete, then go to step 24.
- If no clicking sound is heard, go to step 11.

11. Remove the nuts securing the shift cable bracket (A).

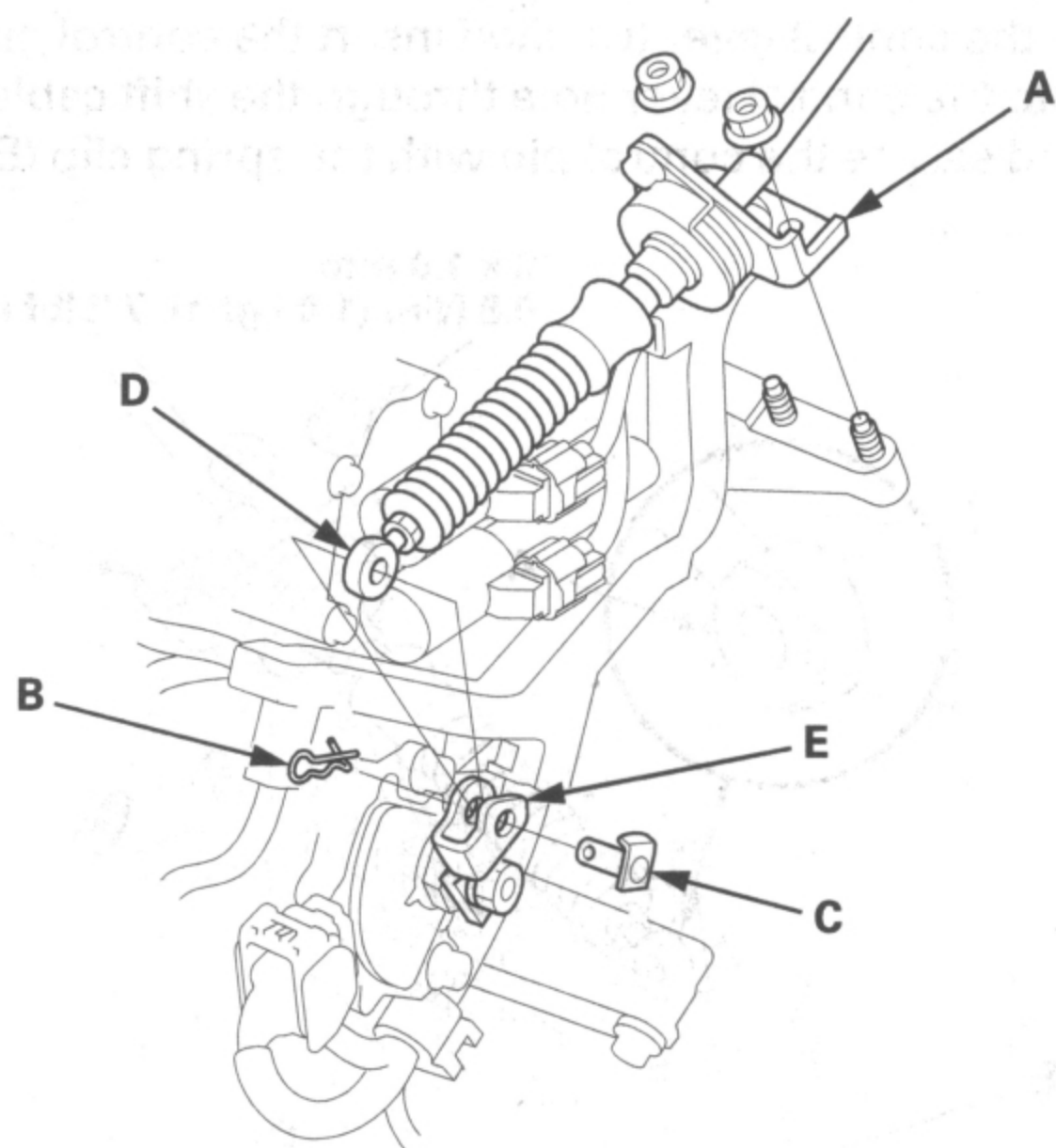

12. Remove the spring clip (B) and the control pin (C), then separate the shift cable end (D) from the selector control lever (E).

13. Remove the bolt securing the harness cover (A).

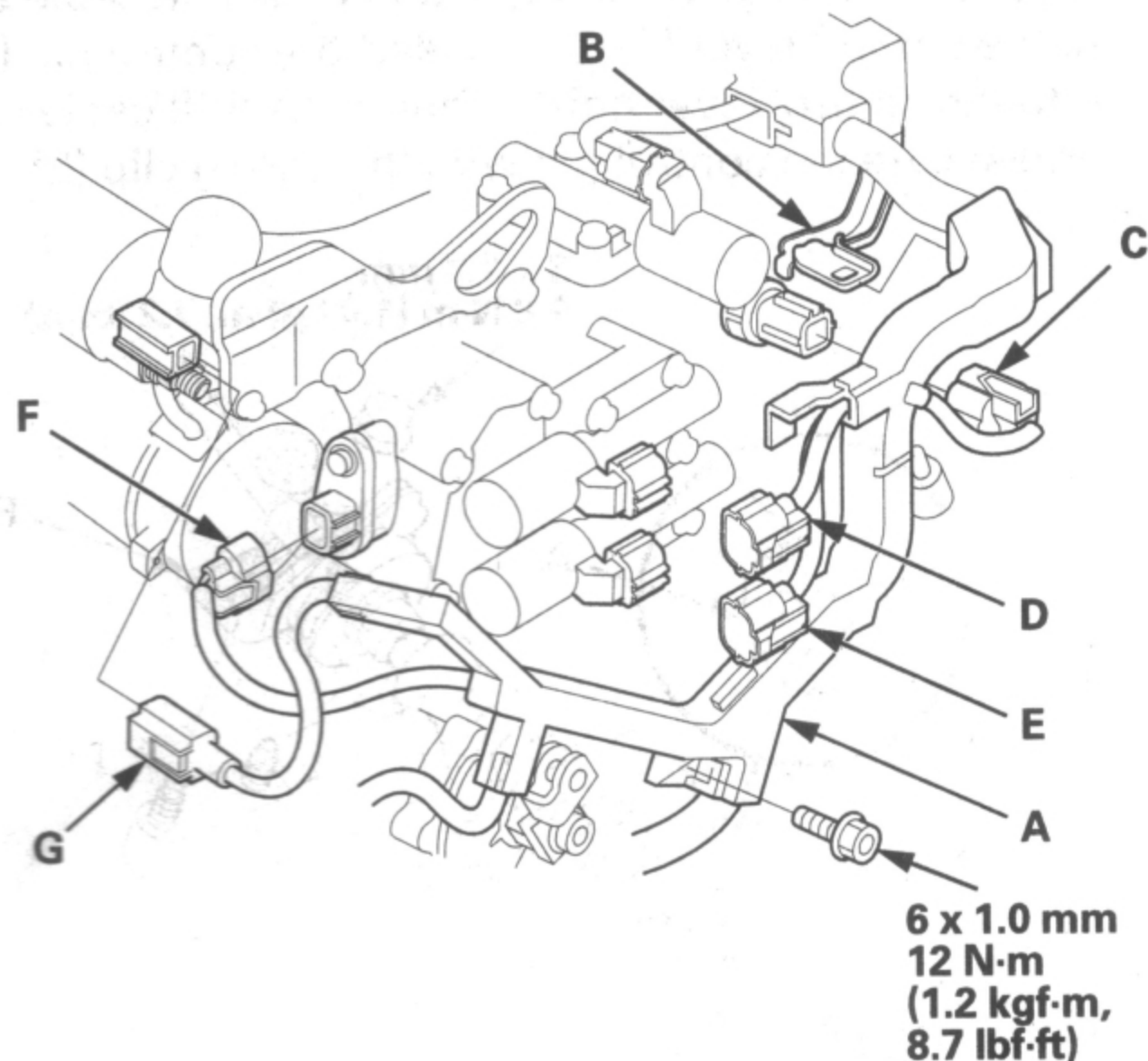

6 x 1.0 mm  
12 N·m  
(1.2 kgf·m,  
8.7 lbf·ft)

14. Remove the harness cover/clamp bracket (B), disconnect the 4th clutch transmission fluid pressure switch connector (C), then remove the harness cover from the bracket.

15. Disconnect the A/T clutch pressure control solenoid valve A connector (D), the A/T clutch pressure control solenoid valve B connector (E), the shift solenoid wire harness connector (F), and the S terminal connector ('08-10 models) (G).

16. Remove A/T clutch pressure control solenoid valves A and B, the ATF pipes (C), the gasket (D), and the O-rings (E). Note the lengths and the locations of the ATF pipes.

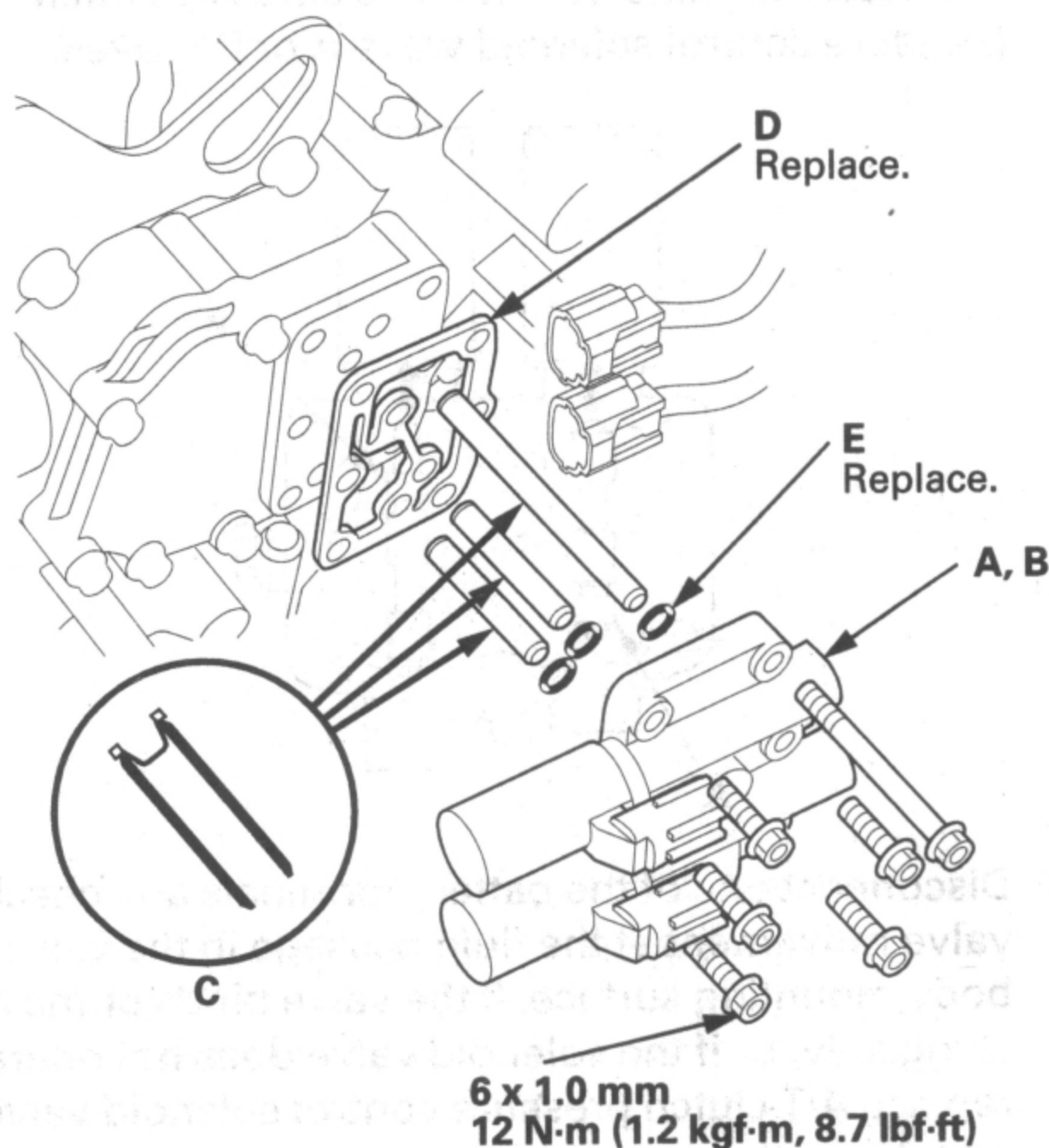

17. Check the fluid passage of the solenoid valve for contamination.

18. Connect a jumper wire from the negative battery terminal to A/T clutch pressure control solenoid valve A or B connector terminal No. 2, and connect another jumper wire from the positive battery terminal to the connector terminal No. 1. Make sure A/T clutch pressure control solenoid valve A or B moves.

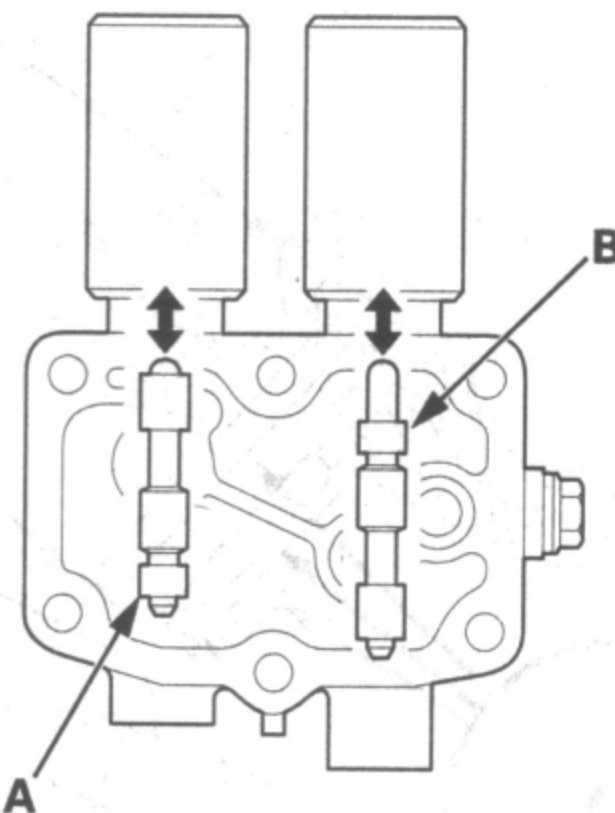

19. Disconnect one of the battery terminals and check the valve movement at the fluid passage in the valve body mounting surface. If the valve binds or moves sluggishly, or if the solenoid valve does not operate, replace A/T clutch pressure control solenoid valves A and B.



20. Clean the mounting surfaces and the fluid passages of the shift solenoid valve body and the solenoid valve cover.

21. Install a new gasket on the shift solenoid valve cover, and install the ATF pipes with the filter end in the transmission housing. Install new O-rings over the ATF pipes.

22. Install A/T clutch pressure control solenoid valves A and B.

23. Install the harness cover on the cover bracket, and secure it with the bolt.

24. Check the connectors for rust, dirt, or oil, and clean or repair if necessary, then connect the connectors securely.

25. Install the harness clamp on the bracket.

26. Apply molybdenum grease to the hole in the bushing (A) in the shift cable end (B). Attach the shift cable end to the control lever (C), then insert the control pin (D) into the control lever hole through the shift cable end, and secure the control pin with the spring clip (E).

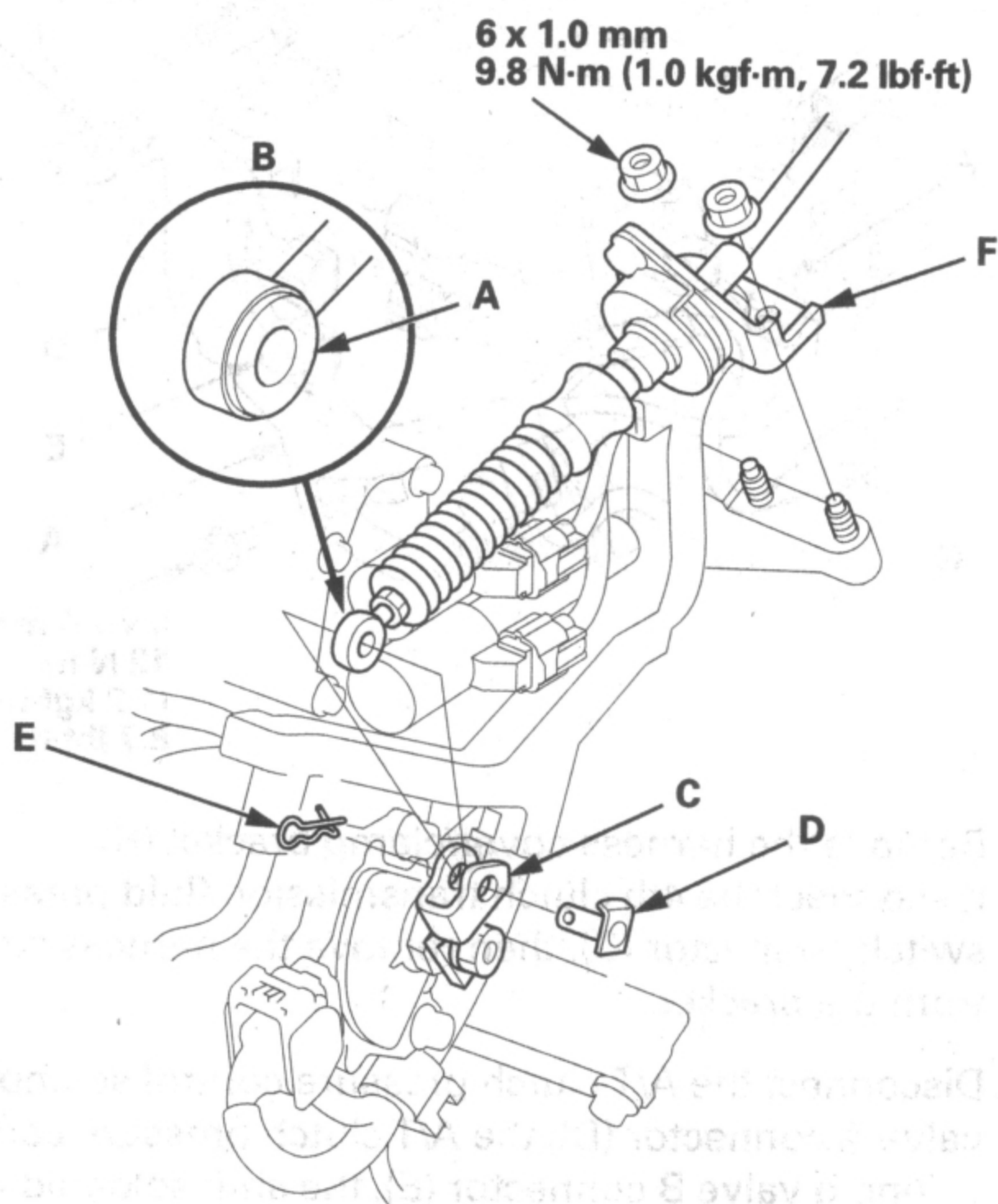

27. Secure the shift cable bracket (F) with the nuts.

28. Install the battery base.

29. Install the air cleaner assembly and the engine cover.

30. Do the battery installation procedure (see page 22-113).

## AT Clutch Pressure Control Solenoid Valve A and B Replacement

1. Do the battery removal procedure (see page 22-113).

2. Remove the engine cover and the air cleaner assembly.

3. Remove the battery base.

4. Remove the nuts securing the shift cable bracket (A).

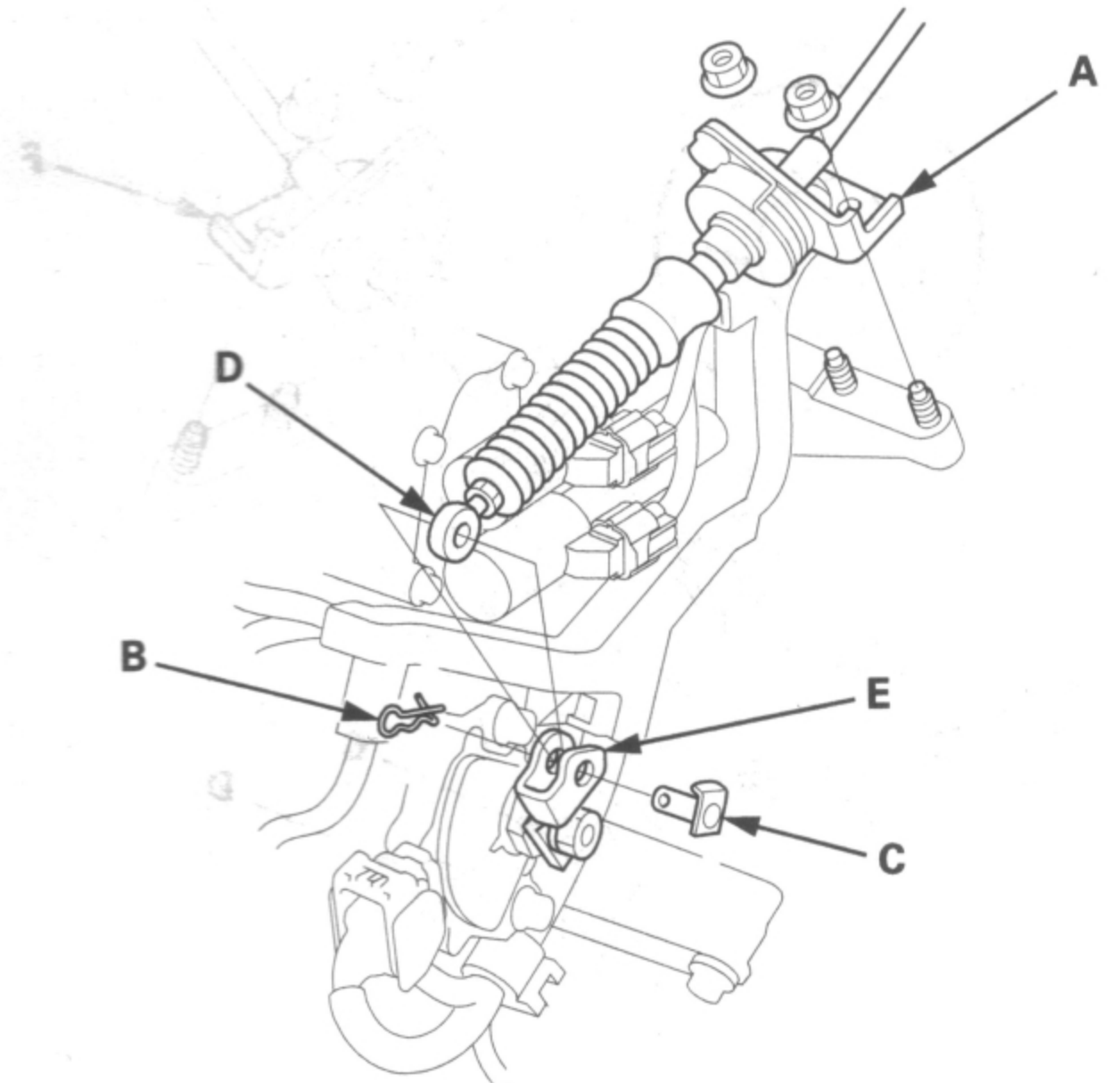

5. Remove the spring clip (B) and the control pin (C), then separate the shift cable end (D) from the selector control lever (E).

6. Remove the bolt securing the harness cover (A).

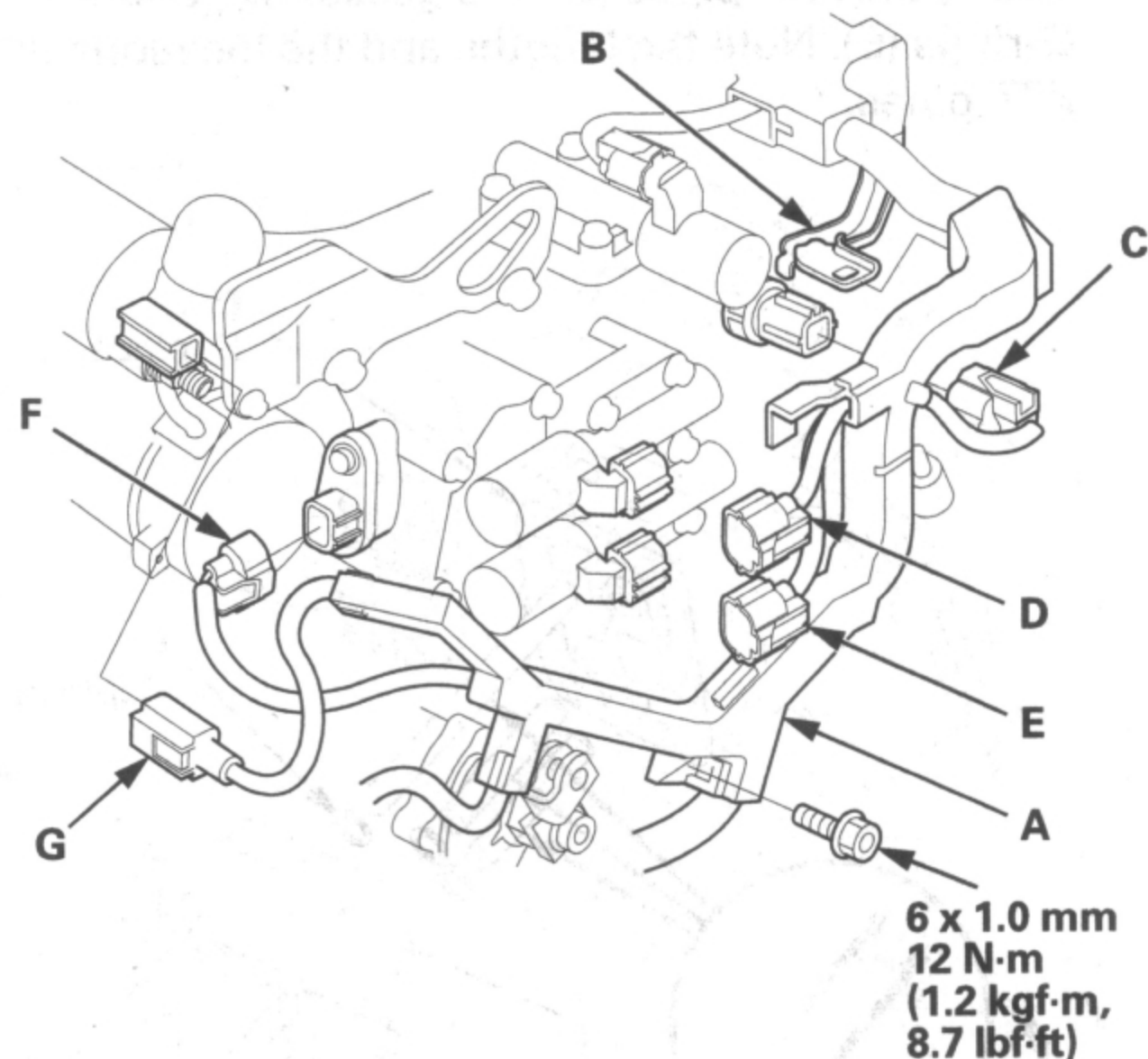

7. Remove the harness cover/clamp bracket (B), disconnect the 4th clutch transmission fluid pressure switch connector (C), then remove the harness cover from the bracket.

8. Disconnect the A/T clutch pressure control solenoid valve A connector (D), the A/T clutch pressure control solenoid valve B connector (E), the shift solenoid wire harness connector (F), and the S terminal connector ('08-10 models) (G).

9. Remove A/T clutch pressure control solenoid valves A and B, the ATF pipes (C), the gasket (D), and the O-rings (E). Note the lengths and the locations of the ATF pipes.

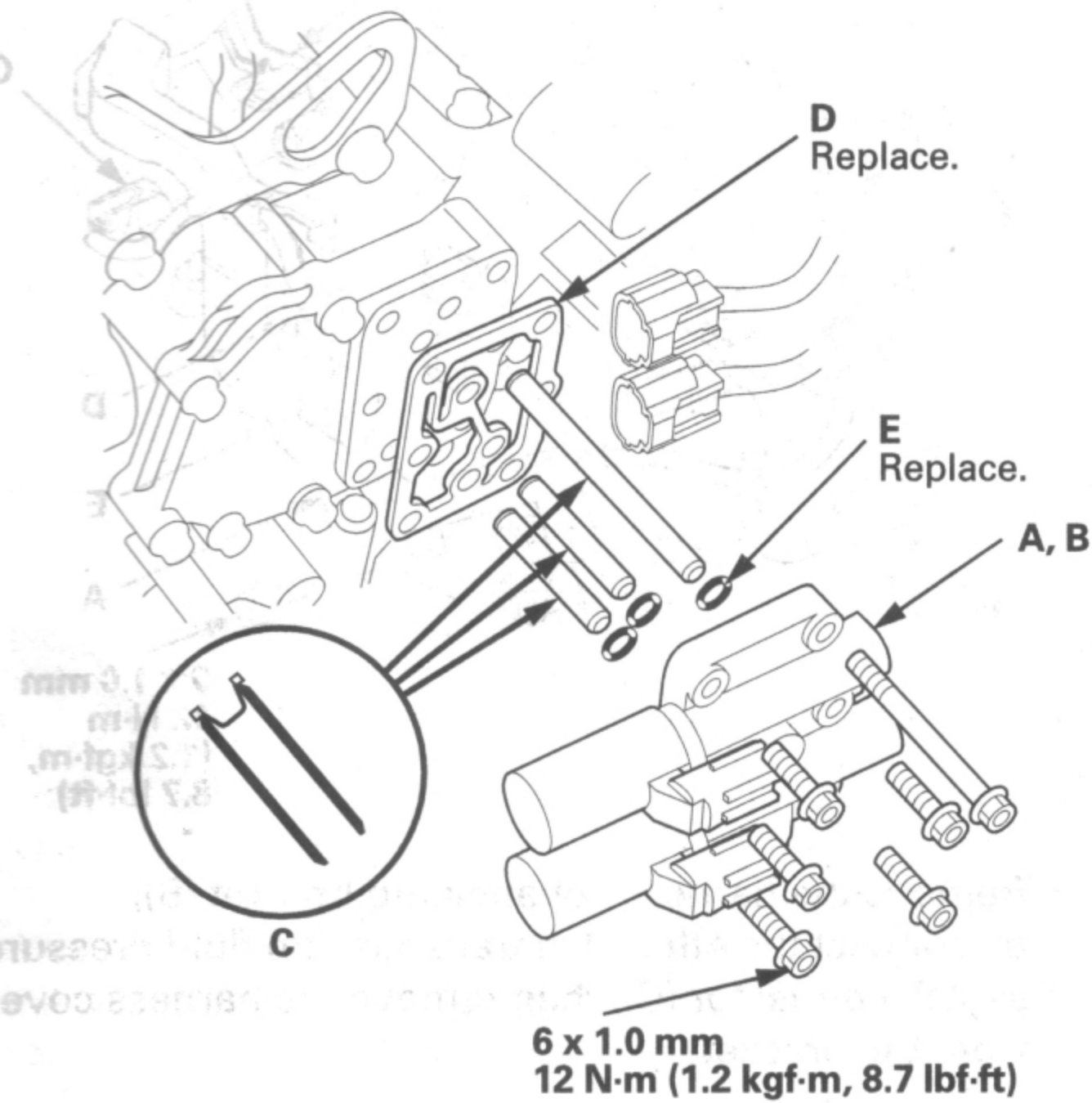

10. Clean the mounting surfaces and the fluid passages of the shift solenoid valve body and the solenoid valve cover.

11. Install a new gasket on the shift solenoid valve cover, and install the ATF pipes with the filter end in the transmission housing. Install new O-rings over the ATF pipes.

12. Install A/T clutch pressure control solenoid valves A and B.

13. Install the harness cover on the cover bracket, and secure it with the bolt.

14. Check the connectors for rust, dirt, or oil, and clean or repair if necessary, then connect the connectors securely.

15. Install the harness clamp on the bracket.

16. Apply molybdenum grease to the hole in the bushing (A) in the shift cable end (B). Attach the shift cable end to the control lever (C), then insert the control pin (D) into the control lever hole through the shift cable end, and secure the control pin with the spring clip (E).

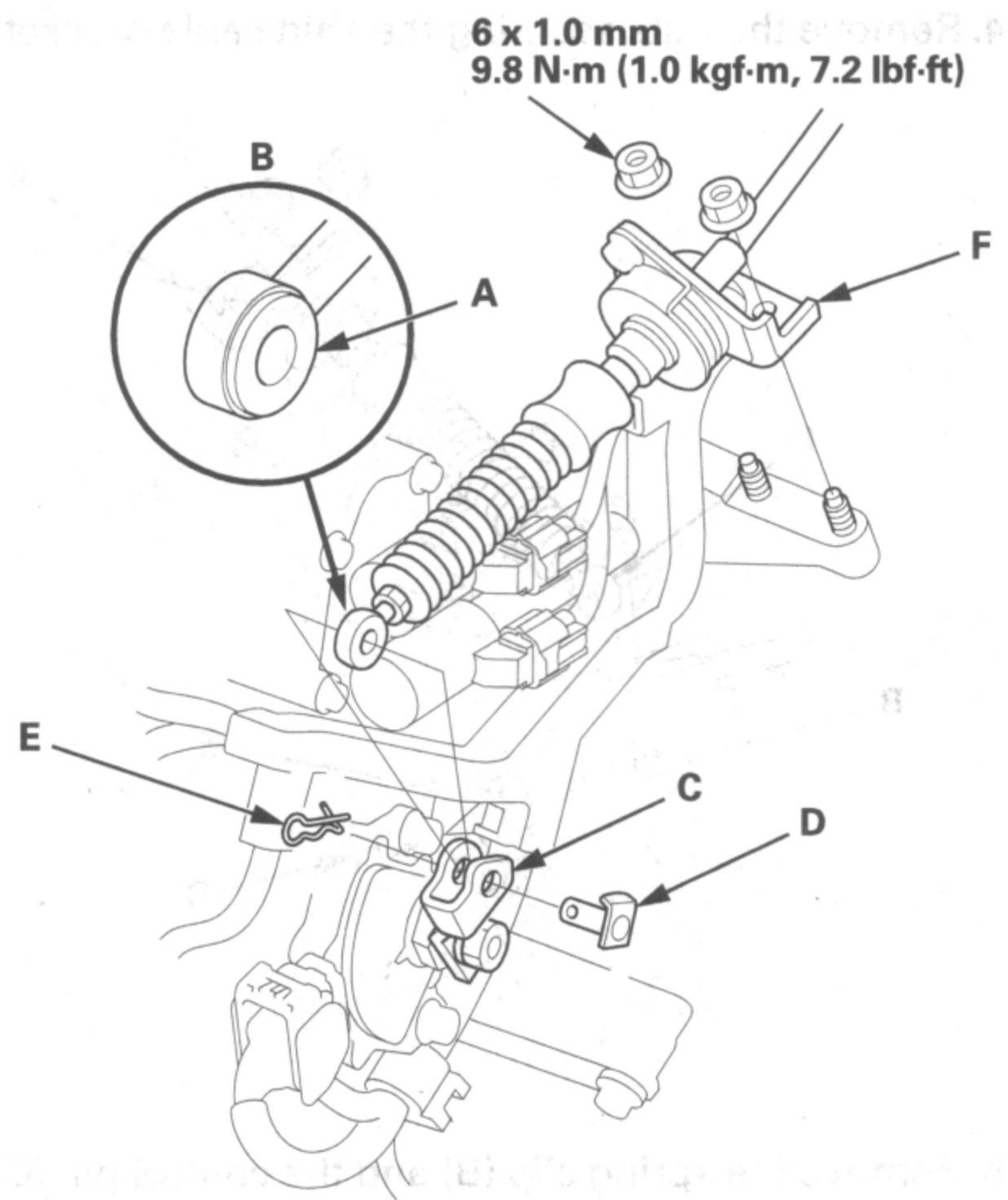

17. Secure the shift cable bracket (F) with the nuts.

18. Install the battery base.

19. Install the air cleaner assembly and the engine cover.

20. Do the battery installation procedure (see page 22-113).

## DTC Troubleshooting

### DTC P0746: A/T Clutch Pressure Control Solenoid Valve A Stuck OFF

### DTC P0747: A/T Clutch Pressure Control Solenoid Valve A Stuck ON

**NOTE:** Before you troubleshoot, record all freeze data and any on-board snapshot with the HDS, and review General Troubleshooting Information (see page 14-4).

1. Warm up the engine to normal operating temperature (the radiator fan comes on).
2. Make sure that the transmission is filled to the proper level, and check for fluid leaks.
3. Drain the ATF (see step 3 on page 14-201) through a strainer. Inspect the strainer for metal debris or excessive clutch material.

*Does the strainer have metal debris or excessive clutch material?*

**YES**—Replace the transmission, then go to step 13.

**NO**—Replace the ATF (see step 5 on page 14-201), then go to step 4.

4. Turn the ignition switch to ON (II).

5. Clear the DTC with the HDS.

6. Test-drive the vehicle with the shift lever in D, and let the transmission shift through all five gears.



7. Monitor the OBD STATUS for P0746 or P0747 in the DTCs MENU with the HDS.

*Does the HDS indicate FAILED?*

**YES**—Go to step 8.

**NO**—If the HDS indicates PASSED, intermittent failure, the system is OK at this time. If the HDS indicates NOT COMPLETED, go to step 6.

8. Clear the DTC with the HDS.

9. Select Clutch Pressure Control (Linear) Solenoid Valve A in the Miscellaneous Test Menu, and test A/T clutch pressure control solenoid valve A with the HDS.

*Does the HDS indicate NORMAL?*

**YES**—Intermittent failure, the system is OK at this time. ■

**NO**—Follow the instructions indicated on the HDS according to the test result. If the HDS has not determined the cause of the failure, go to step 10. If any part was replaced, go to step 11.

10. Inspect A/T clutch pressure control solenoid valve A (see page 14-185).

*Does A/T clutch pressure control solenoid valve A work properly?*

**YES**—Repair the hydraulic system related to CPC valve A, or replace the transmission, then go to step 13.

**NO**—Replace A/T clutch pressure control solenoid valve A (see page 14-189), then go to step 11.

11. Turn the ignition switch to ON (II).

12. Clear the DTC with the HDS.

13. Test-drive the vehicle with the shift lever in D, and let the transmission shift through all five gears.

14. Check for Pending or Confirmed DTCs with the HDS.

*Is DTC P0746 or P0747 indicated?*

**YES**—Go to step 8.

**NO**—Go to step 15.

15. Monitor the OBD STATUS for P0746 or P0747 in the DTCs MENU with the HDS.

*Does the HDS indicate PASSED?*

**YES**—Troubleshooting is complete. If any other Pending or Confirmed DTCs were indicated in step 14, go to the indicated DTC's troubleshooting. ■

**NO**—If the HDS indicates FAILED, go to step 8. If the HDS indicates NOT COMPLETED, go to step 13.

**DTC P0776: A/T Clutch Pressure Control Solenoid Valve B Stuck OFF**

**DTC P0777: A/T Clutch Pressure Control Solenoid Valve B Stuck ON**

**NOTE:** Before you troubleshoot, record all freeze data and any on-board snapshot with the HDS, and review General Troubleshooting Information (see page 14-4).

1. Warm up the engine to normal operating temperature (the radiator fan comes on).

2. Make sure that the transmission is filled to the proper level, and check for fluid leaks.

3. Drain the ATF (see step 3 on page 14-201) through a strainer. Inspect the strainer for metal debris or excessive clutch material.

*Does the strainer have metal debris or excessive clutch material?*

**YES**—Replace the transmission, then go to step 13.

**NO**—Replace the ATF (see step 5 on page 14-201), then go to step 4.

4. Turn the ignition switch to ON (II).

5. Clear the DTC with the HDS.

6. Test-drive the vehicle with the shift lever in D, and let the transmission shift through all five gears.

7. Monitor the OBD STATUS for P0776 or P0777 in the DTCs MENU with the HDS.

*Does the HDS indicate FAILED?*

**YES**—Go to step 8.

**NO**—If the HDS indicates PASSED, intermittent failure, the system is OK at this time. If the HDS indicates NOT COMPLETED, go to step 6.

8. Clear the DTC with the HDS.

9. Select Clutch Pressure Control (Linear) Solenoid Valve B in the Miscellaneous Test Menu, and test A/T clutch pressure control solenoid valve B with the HDS.

*Does the HDS indicate NORMAL?*

**YES**—Intermittent failure, the system is OK at this time. ■

**NO**—Follow the instructions indicated on the HDS according to the test result. If the HDS has not determined the cause of the failure, go to step 10. If any part was replaced, go to step 11.

10. Inspect A/T clutch pressure control solenoid valve B (see page 14-185).

*Does A/T clutch pressure control solenoid valve B work properly?*

**YES**—Repair the hydraulic system related to CPC valve B and shift valve D, or replace the transmission, then go to step 13.

**NO**—Replace A/T clutch pressure control solenoid valve B (see page 14-189), then go to step 13.



11. Turn the ignition switch to ON (II).
12. Clear the DTC with the HDS.
13. Test-drive the vehicle with the shift lever in D, and let the transmission shift through all five gears.
14. Check for Pending or Confirmed DTCs with the HDS.

*Is DTC P0776 or P0777 indicated?*

**YES**—Go to step 8.

**NO**—Go to step 15.

15. Monitor the OBD STATUS for P0776 or P0777 in the DTCs MENU with the HDS.

*Does the HDS indicate PASSED?*

**YES**—Troubleshooting is complete. If any other Pending or Confirmed DTCs were indicated in step 14, go to the indicated DTC's troubleshooting. ■

**NO**—If the HDS indicates FAILED, go to step 8. If the HDS indicates NOT COMPLETED, go to step 13.

## DTC P0962: Problem in A/T Clutch Pressure Control Solenoid Valve A Circuit

### NOTE:

- Before you troubleshoot, record all freeze data and any on-board snapshot with the HDS, and review General Troubleshooting Information (see page 14-4).
- This code is caused by an electrical circuit problem and cannot be caused by a mechanical problem in the transmission.

1. Turn the ignition switch to ON (II).
2. Clear the DTC with the HDS.
3. Start the engine, and wait for at least 1 second.
4. Check for Pending or Confirmed DTCs with the HDS.

*Is DTC P0962 indicated?*

**YES**—Go to step 8.

**NO**—Go to step 5.

5. Select Clutch Pressure Control Solenoid valve A in the Miscellaneous Test Menu, and test A/T clutch pressure control solenoid valve A with the HDS.

*Does the HDS indicate NORMAL?*

**YES**—Go to step 6.

**NO**—Go to step 8.

6. In the Clutch Pressure Control Solenoid Valve Control menu, select A/T Clutch Pressure Control Solenoid Valve A at 1.0 A.

7. Monitor the OBD STATUS for P0962 in the DTCs MENU with the HDS.

*Does the HDS indicate FAILED?*

**YES**—Go to step 8.

**NO**—If the HDS indicates PASSED, intermittent failure, the system is OK at this time. Check for poor connections or loose terminals between A/T clutch pressure control solenoid valve A and the PCM. If the HDS indicates NOT COMPLETED, go to step 5.

8. Turn the ignition switch to LOCK (0).
9. Disconnect the A/T clutch pressure control solenoid valve A connector.
10. Measure the resistance between A/T clutch pressure control solenoid valve A connector terminals No. 1 and No. 2.

### A/T CLUTCH PRESSURE CONTROL SOLENOID VALVE A CONNECTOR

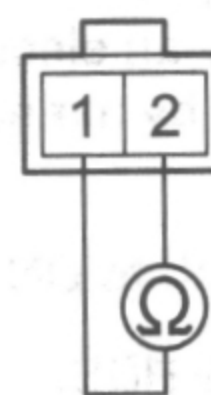

Terminal side of male terminals

*Is there 3—10 Ω?*

**YES**—Go to step 11.

**NO**—Replace A/T clutch pressure control solenoid valve A (see page 14-189), then go to step 22.

11. Check for continuity between A/T clutch pressure control solenoid valve A connector terminal No. 2 and body ground.

### A/T CLUTCH PRESSURE CONTROL SOLENOID VALVE A CONNECTOR

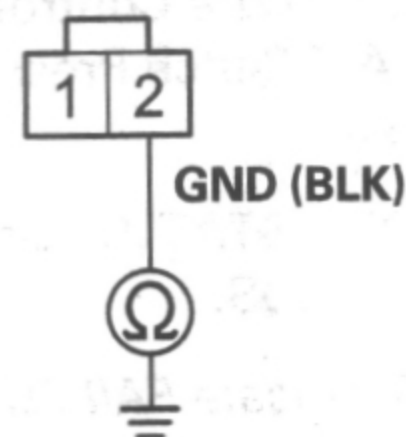

Wire side of female terminals

*Is there continuity?*

**YES**—Go to step 12.

**NO**—Repair open in the wire between A/T clutch pressure control solenoid valve A and body ground (G101) (see page 22-23), or repair poor body ground (G101) (see page 22-23), then go to step 19.



12. Jump the SCS line with the HDS.

13. Disconnect PCM connector C (49P).

14. Check for continuity between A/T clutch pressure control solenoid valve A connector terminal No. 1 and body ground.

#### A/T CLUTCH PRESSURE CONTROL SOLENOID VALVE A CONNECTOR

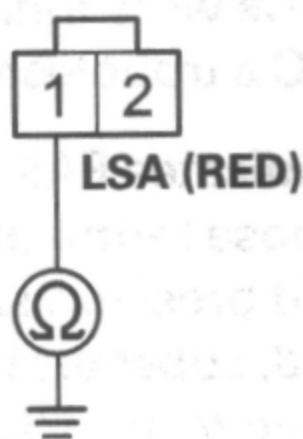

Wire side of female terminals

Is there continuity?

**YES**—Repair short to body ground in the wire between PCM connector terminal C21 and A/T clutch pressure control solenoid valve A, then go to step 19.

**NO**—Go to step 15.

15. Check for continuity between A/T clutch pressure control solenoid valve A connector terminal No. 1 and PCM connector terminal C21.

#### PCM CONNECTOR C (49P)

#### A/T CLUTCH PRESSURE CONTROL SOLENOID VALVE A CONNECTOR

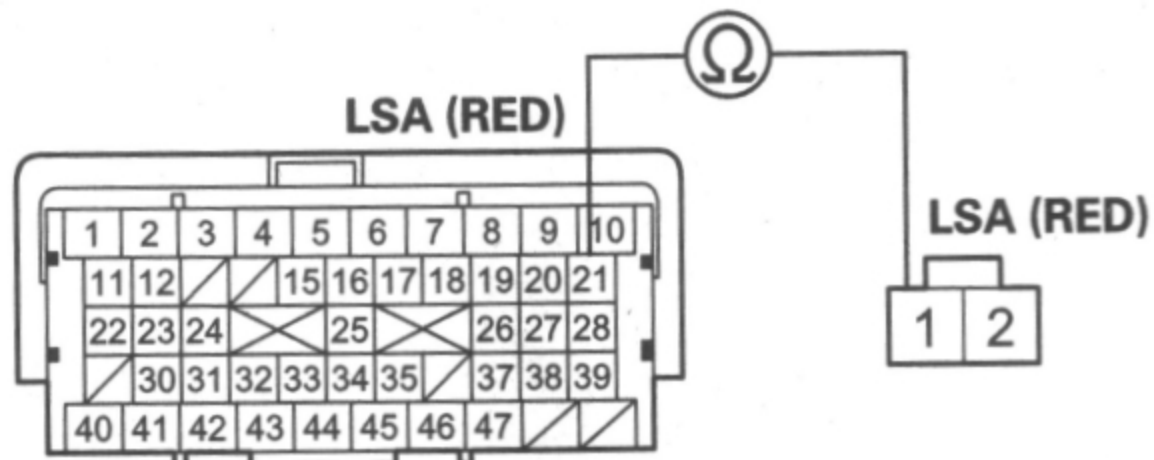

Terminal side of female terminals

Wire side of female terminals

Is there continuity?

**YES**—Go to step 16.

**NO**—Repair open in the wire between A/T clutch pressure control solenoid valve A connector terminal No. 1 and PCM connector terminal C21, then go to step 19.

16. Disconnect PCM connector B (49P).

17. Turn the ignition switch to ON (II).

18. Measure the voltage between PCM connector terminal B2 and body ground.

#### PCM CONNECTOR B (49P)

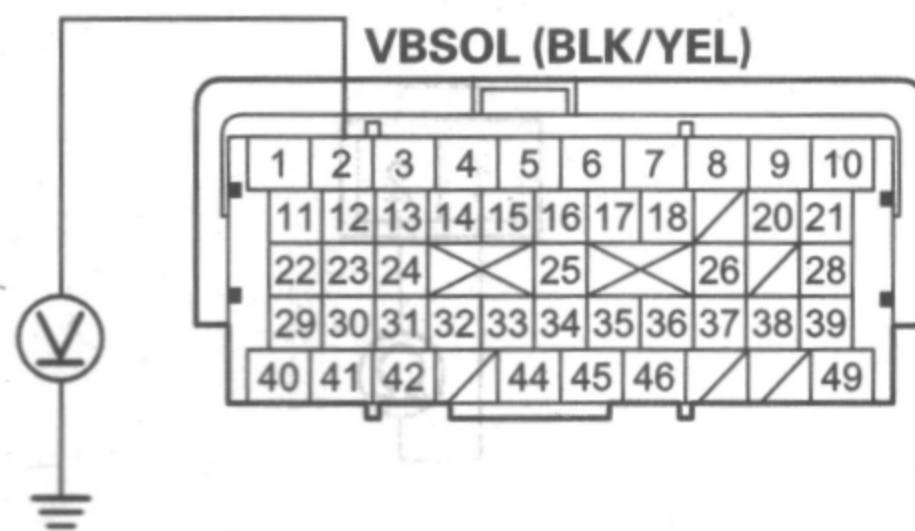

Terminal side of female terminals

Is there battery voltage?

**YES**—Go to step 25.

**NO**—Check for a blown No. 18 (15 A) fuse in the driver's under-dash fuse/relay box. If the fuse is OK, repair open in the wire between PCM connector terminal B2 and the driver's under-dash fuse/relay box, then go to step 19.

19. Reconnect all connectors.

20. Turn the ignition switch to ON (II).

21. Clear the DTC with the HDS.

22. Start the engine, and wait for at least 1 second.

23. Check for Pending or Confirmed DTCs with the HDS.

Is DTC P0962 indicated?

**YES**—Check for poor connections or loose terminals between A/T clutch pressure control solenoid valve A and the PCM, then go to step 1.

**NO**—Go to step 24.

24. Monitor the OBD STATUS for P0962 in the DTCs MENU with the HDS.

Does the HDS indicate PASSED?

**YES**—Troubleshooting is complete. If any other Pending or Confirmed DTCs were indicated in step 23, go to the indicated DTC's troubleshooting. ■

**NO**—If the HDS indicates FAILED, check for poor connections or loose terminals between A/T clutch pressure control solenoid valve A and the PCM, then go to step 1. If the HDS indicates NOT COMPLETED, go to step 22.

25. Reconnect all connectors.

26. Update the PCM if it does not have the latest software (see page 11-292), or substitute a known-good PCM (see page 11-7).

27. Start the engine, and wait for at least 1 second.



28. Check for Pending or Confirmed DTCs with the HDS.

*Is DTC P0962 indicated?*

**YES**—Check for poor connections or loose terminals between A/T clutch pressure control solenoid valve A and the PCM. If the PCM was updated, substitute a known-good PCM (see page 11-7), then go to step 27. If the PCM was substituted, go to step 1.

**NO**—Go to step 29.

29. Monitor the OBD STATUS for P0962 in the DTCs MENU with the HDS.

*Does the HDS indicate PASSED?*

**YES**—If the PCM was updated, troubleshooting is complete. If the PCM was substituted, replace the original PCM (see page 11-294). If any other Pending or Confirmed DTCs were indicated in step 28, go to the indicated DTC's troubleshooting. ■

**NO**—If the HDS indicates FAILED, check for poor connections or loose terminals between A/T clutch pressure control solenoid valve A and the PCM. If the PCM was updated, substitute a known-good PCM (see page 11-7), then go to step 27. If the PCM was substituted, go to step 1. If the HDS indicates NOT COMPLETED, go to step 27.

## DTC P0963: Problem in A/T Clutch Pressure Control Solenoid Valve A

### NOTE:

- Before you troubleshoot, record all freeze data and any on-board snapshot with the HDS, and review General Troubleshooting Information (see page 14-4).
- This code is caused by an electrical circuit problem and cannot be caused by a mechanical problem in the transmission.

1. Turn the ignition switch to ON (II).
2. Clear the DTC with the HDS.
3. Start the engine, and wait for at least 1 second.
4. Check for Pending or Confirmed DTCs with the HDS.

*Is DTC P0963 indicated?*

**YES**—Go to step 8.

**NO**—Go to step 5.

5. Select Clutch Pressure Control Solenoid Valve A in the Miscellaneous Test Menu, and test A/T clutch pressure control solenoid valve A with the HDS.

*Does the HDS indicate NORMAL?*

**YES**—Go to step 6.

**NO**—Go to step 8.

6. In the Clutch Pressure Control Solenoid Valve Control menu, select A/T Clutch Pressure Control Solenoid Valve A at 0.2 A.

7. Monitor the OBD STATUS for P0963 in the DTCs MENU with the HDS.

*Does the HDS indicate FAILED?*

**YES**—Go to step 8.

**NO**—If the HDS indicates PASSED, intermittent failure, the system is OK at this time. Check for poor connections or loose terminals between A/T clutch pressure control solenoid valve A and the PCM. If the HDS indicates NOT COMPLETED, go to step 5.

8. Turn the ignition switch to LOCK (0).

9. Disconnect the A/T clutch pressure control solenoid valve A connector.

10. Measure the resistance between A/T clutch pressure control solenoid valve A connector terminals No. 1 and No. 2.

### A/T CLUTCH PRESSURE CONTROL SOLENOID VALVE A CONNECTOR

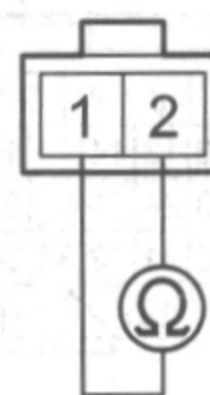

Terminal side of male terminals

*Is there 3—10 Ω?*

**YES**—Go to step 14.

**NO**—Replace A/T clutch pressure control solenoid valve A (see page 14-189), then go to step 11.

11. Start the engine, and wait for at least 1 second.
12. Check for Pending or Confirmed DTCs with the HDS.

*Is DTC P0963 indicated?*

**YES**—Check for poor connections or loose terminals between A/T clutch pressure control solenoid valve A and the PCM, then go to step 1.

**NO**—Go to step 13.

13. Monitor the OBD STATUS for P0963 in the DTCs MENU with the HDS.

*Does the HDS indicate PASSED?*

**YES**—Troubleshooting is complete. If any other Pending or Confirmed DTCs were indicated in step 12, go to the indicated DTC's troubleshooting. ■

**NO**—If the HDS indicates FAILED, check for poor connections or loose terminals between A/T clutch pressure control solenoid valve A and the PCM, then go to step 1. If the HDS indicates NOT COMPLETED, go to step 11.



14. Reconnect all connectors.
15. Update the PCM if it does not have the latest software (see page 11-292), or substitute a known-good PCM (see page 11-7).
16. Start the engine, and wait for at least 1 second.
17. Check for Pending or Confirmed DTCs with the HDS.

*Is DTC P0963 indicated?*

**YES**—Check for poor connections or loose terminals between A/T clutch pressure control solenoid valve A and the PCM. If the PCM was updated, substitute a known-good PCM (see page 11-7), then go to step 16. If the PCM was substituted, go to step 1.

**NO**—Go to step 18.

18. Monitor the OBD STATUS for P0963 in the DTCs MENU with the HDS.

*Does the HDS indicate PASSED?*

**YES**—If the PCM was updated, troubleshooting is complete. If the PCM was substituted, replace the original PCM (see page 11-294). If any other Pending or Confirmed DTCs were indicated in step 17, go to the indicated DTC's troubleshooting. ■

**NO**—If the HDS indicates FAILED, check for poor connections or loose terminals between A/T clutch pressure control solenoid valve A and the PCM. If the PCM was updated, substitute a known-good PCM (see page 11-7), then go to step 16. If the PCM was substituted, go to step 1. If the HDS indicates NOT COMPLETED, go to step 16.

## DTC P0966: Problem in A/T Clutch Pressure Control Solenoid Valve B Circuit

### NOTE:

- Before you troubleshoot, record all freeze data and any on-board snapshot with the HDS, and review General Troubleshooting Information (see page 14-4).
- This code is caused by an electrical circuit problem and cannot be caused by a mechanical problem in the transmission.

1. Turn the ignition switch to ON (II).
2. Clear the DTC with the HDS.
3. Start the engine, and wait for at least 1 second.
4. Check for Pending or Confirmed DTCs with the HDS.

*Is DTC P0966 indicated?*

**YES**—Go to step 8.

**NO**—Go to step 5.

5. Select Clutch Pressure Control Solenoid Valve B in the Miscellaneous Test Menu, and test A/T clutch pressure control solenoid valve B with the HDS.

*Does the HDS indicate NORMAL?*

**YES**—Go to step 6.

**NO**—Go to step 8.

6. In the Clutch Pressure Control Solenoid Valve control menu, select A/T Clutch Pressure Control Solenoid Valve B at 1.0 A.

7. Monitor the OBD STATUS for P0966 in the DTCs MENU with the HDS.

*Does the HDS indicate FAILED?*

**YES**—Go to step 8.

**NO**—If the HDS indicates PASSED, intermittent failure, the system is OK at this time. Check for poor connections or loose terminals between A/T clutch pressure control solenoid valve B and the PCM. If the HDS indicates NOT COMPLETED, go to step 5.

8. Turn the ignition switch to LOCK (0).
9. Disconnect the A/T clutch pressure control solenoid valve B connector.
10. Measure the resistance between A/T clutch pressure control solenoid valve B connector terminals No. 1 and No. 2.

### A/T CLUTCH PRESSURE CONTROL SOLENOID VALVE B CONNECTOR

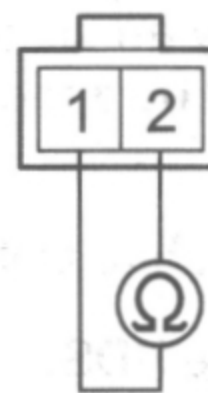

Terminal side of male terminals

*Is there 3–10 Ω?*

**YES**—Go to step 11.

**NO**—Replace A/T clutch pressure control solenoid valve B (see page 14-189), then go to step 21.

11. Check for continuity between A/T clutch pressure control solenoid valve B connector terminal No. 2 and body ground.

### A/T CLUTCH PRESSURE CONTROL SOLENOID VALVE B CONNECTOR

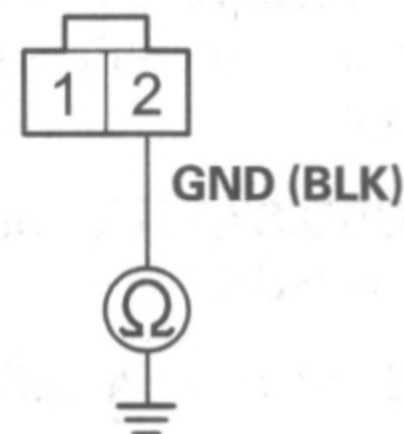

Wire side of female terminals

*Is there continuity?*

**YES**—Go to step 12.

**NO**—Repair open in the wire between A/T clutch pressure control solenoid valve B and body ground body ground (G101) (see page 22-23), or repair poor body ground (G101) (see page 22-23), then go to step 18.



12. Jump the SCS line with the HDS.
13. Disconnect PCM connector B (49P).
14. Check for continuity between A/T clutch pressure control solenoid valve B connector terminal No. 1 and body ground.

**A/T CLUTCH PRESSURE CONTROL SOLENOID VALVE B CONNECTOR**

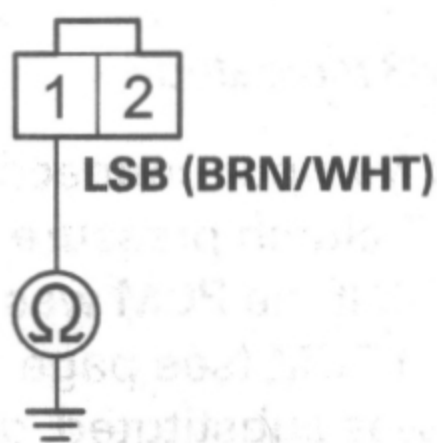

Wire side of female terminals

*Is there continuity?*

**YES**—Repair short to body ground in the wire between PCM connector terminal B10 and A/T clutch pressure control solenoid valve B, then go to step 18.

**NO**—Go to step 15.

15. Check for continuity between A/T clutch pressure control solenoid valve B connector terminal No. 1 and PCM connector terminal B10.

**PCM CONNECTOR B (49P) A/T CLUTCH PRESSURE CONTROL SOLENOID VALVE B CONNECTOR**

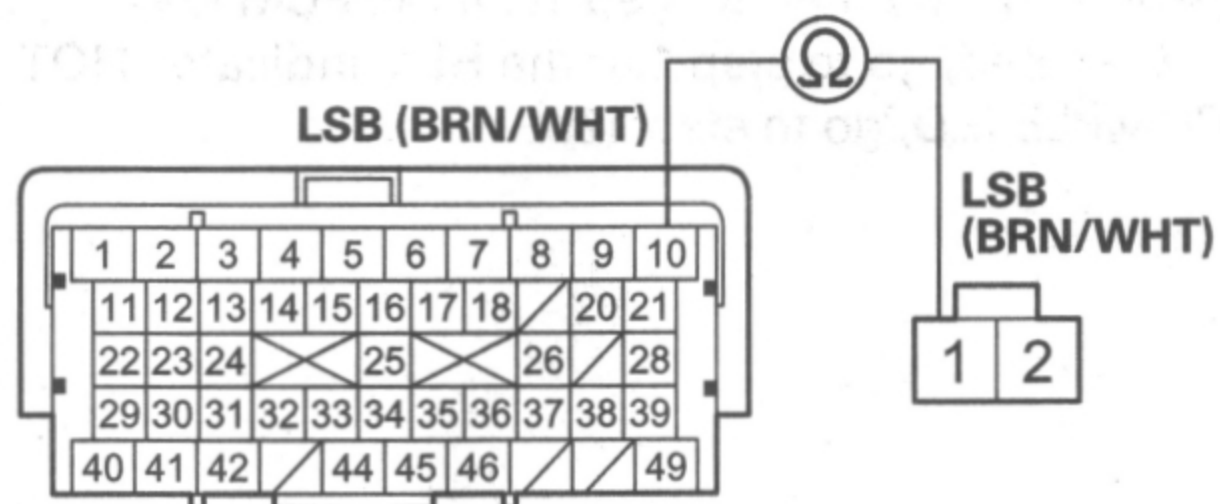

Terminal side of female terminals

Wire side of female terminals

*Is there continuity?*

**YES**—Go to step 16.

**NO**—Repair open in the wire between A/T clutch pressure control solenoid valve B connector terminal No. 1 and PCM connector terminal B10, then go to step 18.

16. Turn the ignition switch to ON (II).

17. Measure the voltage between PCM connector terminal B2 and body ground.

**PCM CONNECTOR B (49P)**

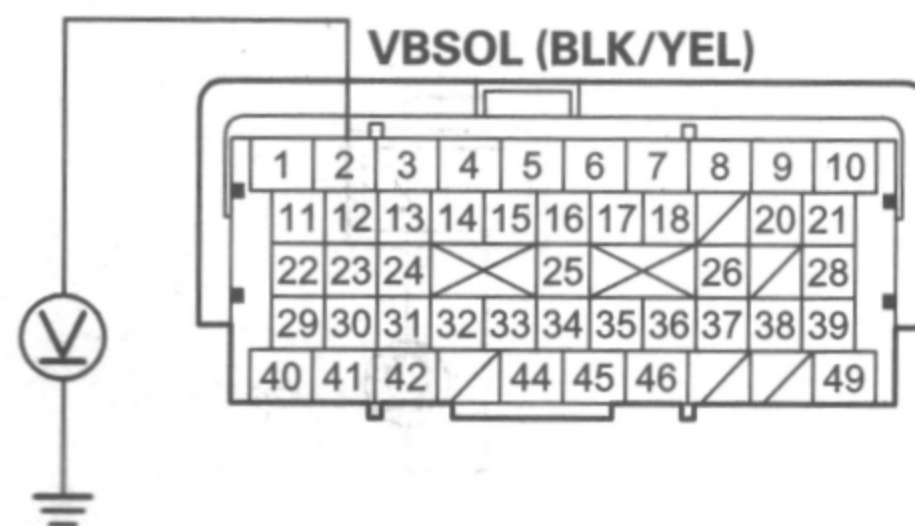

Terminal side of female terminals

*Is there battery voltage?*

**YES**—Go to step 24.

**NO**—Check for a blown No. 18 (15 A) fuse in the driver's under-dash fuse/relay box. If the fuse is OK, repair open in the wire between PCM connector terminal B2 and the driver's under-dash fuse/relay box, then go to step 18.

18. Reconnect all connectors.
19. Turn the ignition switch to ON (II).
20. Clear the DTC with the HDS.
21. Start the engine, and wait for at least 1 second.
22. Check for Pending or Confirmed DTCs with the HDS.

*Is DTC P0966 indicated?*

**YES**—Check for poor connections or loose terminals between A/T clutch pressure control solenoid valve B and the PCM, then go to step 1.

**NO**—Go to step 23.

23. Monitor the OBD STATUS for P0966 in the DTCs MENU with the HDS.

*Does the HDS indicate PASSED?*

**YES**—Troubleshooting is complete. If any other Pending or Confirmed DTCs were indicated in step 22, go to the indicated DTC's troubleshooting. ■

**NO**—If the HDS indicates FAILED, check for poor connections or loose terminals between A/T clutch pressure control solenoid valve B and the PCM, then go to step 1. If the HDS indicates NOT COMPLETED, go to step 21.

24. Reconnect all connectors.
25. Update the PCM if it does not have the latest software (see page 11-292), or substitute a known-good PCM (see page 11-7).
26. Start the engine, and wait for at least 1 second.



27. Check for Pending or Confirmed DTCs with the HDS.

*Is DTC P0966 indicated?*

**YES**—Check for poor connections or loose terminals between A/T clutch pressure control solenoid valve B and the PCM. If the PCM was updated, substitute a known-good PCM (see page 11-7), then go to step 26. If the PCM was substituted, go to step 1.

**NO**—Go to step 28.

28. Monitor the OBD STATUS for P0966 in the DTCs MENU with the HDS.

*Does the HDS indicate PASSED?*

**YES**—If the PCM was updated, troubleshooting is complete. If the PCM was substituted, replace the original PCM (see page 11-294). If any other Pending or Confirmed DTCs were indicated in step 27, go to the indicated DTC's troubleshooting. ■

**NO**—If the HDS indicates FAILED, check for poor connections or loose terminals between A/T clutch pressure control solenoid valve B and the PCM. If the PCM was updated, substitute a known-good PCM (see page 11-7), then go to step 26. If the PCM was substituted, go to step 1. If the HDS indicates NOT COMPLETED, go to step 26.

### DTC P0967: Problem in A/T Clutch Pressure Control Solenoid Valve B

#### NOTE:

- Before you troubleshoot, record all freeze data and any on-board snapshot with the HDS, and review General Troubleshooting Information (see page 14-4).
- This code is caused by an electrical circuit problem and cannot be caused by a mechanical problem in the transmission.

1. Turn the ignition switch to ON (II).
2. Clear the DTC with the HDS.
3. Start the engine, and wait for at least 1 second.
4. Check for Pending or Confirmed DTCs with the HDS.

*Is DTC P0967 indicated?*

**YES**—Go to step 8.

**NO**—Go to step 5.

5. Select Clutch Pressure Control Solenoid Valve B in the Miscellaneous Test Menu, and test A/T clutch pressure control solenoid valve B with the HDS.

*Does the HDS indicate NORMAL?*

**YES**—Go to step 6.

**NO**—Go to step 8.

6. In the Clutch Pressure Control Solenoid Valve control menu, select A/T Clutch Pressure Control Solenoid Valve B at 0.2 A.

7. Monitor the OBD STATUS for P0967 in the DTCs MENU with the HDS.

*Does the HDS indicate FAILED?*

**YES**—Go to step 8.

**NO**—If the HDS indicates PASSED, intermittent failure, the system is OK at this time. Check for poor connections or loose terminals between A/T clutch pressure control solenoid valve B and the PCM. If the HDS indicates NOT COMPLETED, go to step 5.

8. Turn the ignition switch to LOCK (0).
9. Disconnect the A/T clutch pressure control solenoid valve B connector.
10. Measure the resistance between A/T clutch pressure control solenoid valve B connector terminals No. 1 and No. 2.

#### A/T CLUTCH PRESSURE CONTROL SOLENOID VALVE B CONNECTOR

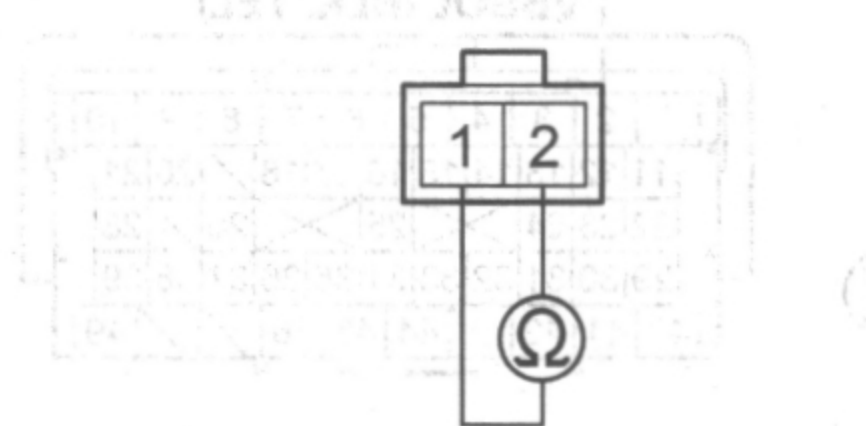

Terminal side of male terminals

*Is there 3–10 Ω?*

**YES**—Go to step 14.

**NO**—Replace A/T clutch pressure control solenoid valve B (see page 14-189), then go to step 11.

11. Start the engine, and wait for at least 1 second.
12. Check for Pending or Confirmed DTCs with the HDS.

*Is DTC P0967 indicated?*

**YES**—Check for poor connections or loose terminals between A/T clutch pressure control solenoid valve B and the PCM, then go to step 1.

**NO**—Go to step 13.

13. Monitor the OBD STATUS for P0967 in the DTCs MENU with the HDS.

*Does the HDS indicate PASSED?*

**YES**—Troubleshooting is complete. If any other Pending or Confirmed DTCs were indicated in step 12, go to the indicated DTC's troubleshooting. ■

**NO**—If the HDS indicates FAILED, check for poor connections or loose terminals between A/T clutch pressure control solenoid valve B and the PCM, then go to step 1. If the HDS indicates NOT COMPLETED, go to step 11.



14. Reconnect all connectors.
15. Update the PCM if it does not have the latest software (see page 11-292), or substitute a known-good PCM (see page 11-7).
16. Start the engine, and wait for at least 1 second.
17. Check for Pending or Confirmed DTCs with the HDS.

*Is DTC P0967 indicated?*

**YES**—Check for poor connections or loose terminals between A/T clutch pressure control solenoid valve B and the PCM. If the PCM was updated, substitute a known-good PCM (see page 11-7), then go to step 16. If the PCM was substituted, go to step 1.

**NO**—Go to step 18.

18. Monitor the OBD STATUS for P0967 in the DTCs MENU with the HDS.

*Does the HDS indicate PASSED?*

**YES**—If the PCM was updated, troubleshooting is complete. If the PCM was substituted, replace the original PCM (see page 11-294). If any other Pending or Confirmed DTCs were indicated in step 17, go to the indicated DTC's troubleshooting. ■

**NO**—If the HDS indicates FAILED, check for poor connections or loose terminals between A/T clutch pressure control solenoid valve B and the PCM. If the PCM was updated, substitute a known-good PCM (see page 11-7), then go to step 16. If the PCM was substituted, go to step 1. If the HDS indicates NOT COMPLETED, go to step 16.