

A/T Clutch Pressure Control Solenoid Valve A Test

1. Connect the HDS to the DLC (A).

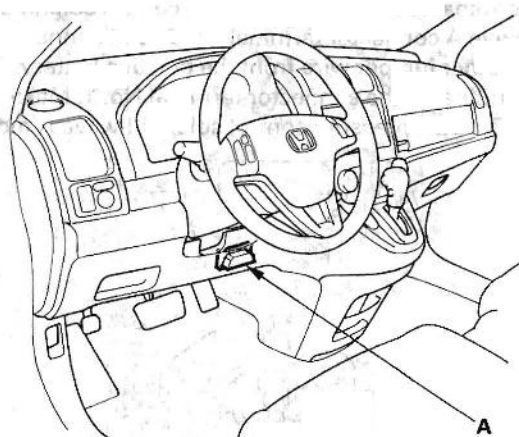

2. Choose Clutch Pressure Control (Linear) Solenoid A in the Miscellaneous Test Menu on the HDS.

NOTE: If the HDS does not communicate with the PCM, troubleshoot the DLC circuit (see page 11-197).

3. Test A/T clutch pressure control solenoid valve A with the HDS.

- If the valve tests OK, the test is complete. Disconnect the HDS.
- If the valve does not test OK, follow the instructions on the HDS.
- If the valve does not test OK, and the HDS does not determine the cause, go to step 4.

4. Remove the air cleaner housing and intake air duct.
5. Disconnect the A/T clutch pressure control solenoid valve A connector.

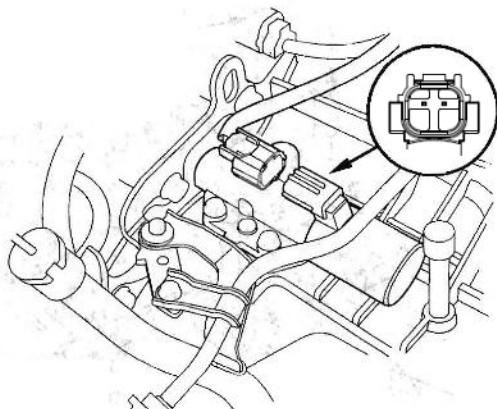

6. Measure the A/T clutch pressure control solenoid valve A resistance at the connector terminals.

Standard: 3—10 Ω

- If the resistance is out of standard, replace A/T clutch pressure control solenoid valve A (see page 14-227).
- If the resistance is within the standard, go to step 7.

7. Connect a jumper wire from the negative battery terminal to the solenoid valve A connector terminal No. 2, and connect another jumper wire from the positive battery terminal to the connector terminal No. 1.

- If a clicking sound is heard, the valve is OK. Reconnect the connector, and install all removed parts.
- If no clicking sound is heard, go to step 8.

8. Remove the mounting bolts and A/T clutch pressure control solenoid valve A.

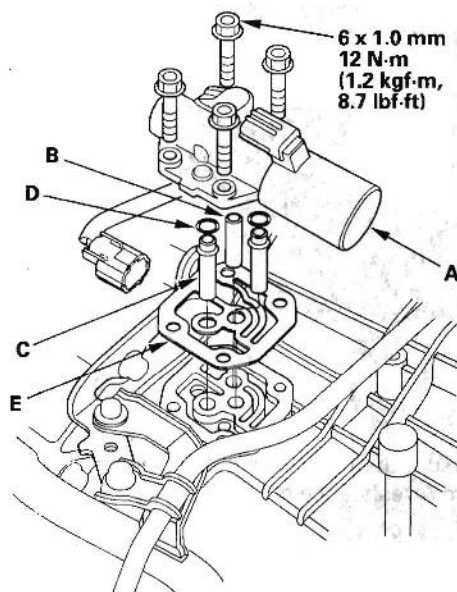

9. Remove the ATF pipe (B), ATF joint pipes (C), O-rings (D), and gasket (E).
10. Check the fluid passage of the solenoid valve for contamination.
11. Connect a jumper wire from the negative battery terminal to A/T clutch pressure control solenoid valve A connector terminal No. 2, and connect another jumper wire from the positive battery terminal to the connector terminal No. 1. Make sure A/T clutch pressure control solenoid valve A moves.

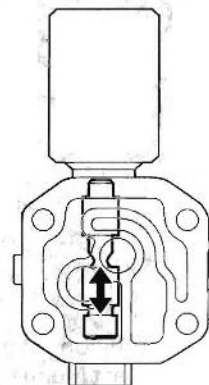

12. Disconnect one of the jumper wires and check valve movement at the fluid passage in valve body mounting surface. If the valve binds or moves sluggishly, or if the solenoid valve does not operate, replace A/T clutch pressure control solenoid valve A.

13. Clean the mounting surface and fluid passage of the solenoid valve body and transmission housing.
14. Install the new gasket on the transmission housing, and install the ATF pipe and ATF joint pipes. Install the new O-rings over the ATF joint pipes.
15. Install A/T clutch pressure control solenoid valve A.
16. Check the connector for rust, dirt, or oil, clean or repair if necessary, then connect the connector securely.
17. Install the intake air duct and air cleaner housing.

A/T Clutch Pressure Control Solenoid Valve A Replacement

1. Remove the air cleaner housing and intake air duct.
2. Disconnect the A/T clutch pressure control solenoid valve A connector.
3. Remove the mounting bolts and A/T clutch pressure control solenoid valve A.

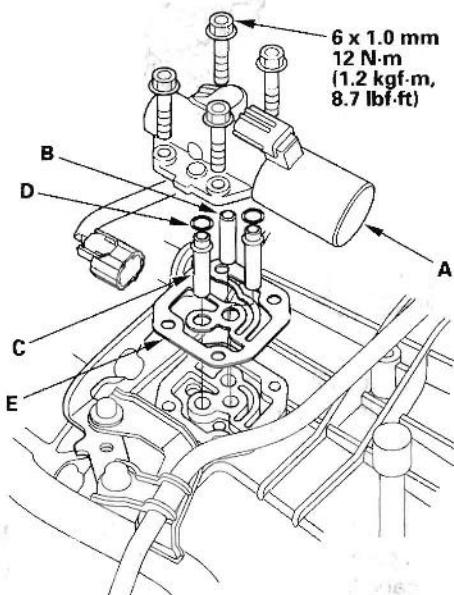

4. Remove the ATF pipe (B), ATF joint pipes (C), O-rings (D), and gasket (E).
5. Clean the mounting surface and fluid passage of the solenoid valve body and transmission housing.
6. Install the new gasket on the transmission housing, and install the ATF pipe and ATF joint pipes. Install the new O-rings over the ATF joint pipes.
7. Install A/T clutch pressure control solenoid valve A.
8. Check the connector for rust, dirt, or oil, then connect the connector securely.
9. Install the intake air duct and air cleaner housing.

DTC Troubleshooting (cont'd)

DTC P0962: Problem in A/T Clutch Pressure Control Solenoid Valve A Circuit

NOTE:

- Before you troubleshoot, record all freeze data and any on-board snapshot, and review General Troubleshooting Information (see page 14-4).
- This code is caused by an electrical circuit problem and cannot be caused by a mechanical problem in the transmission.

1. Clear the DTC with the HDS.
2. Check that DTC P0962 recurs.

Is DTC P0962 indicated?

YES—Go to step 6.

NO—Go to step 3.

3. Choose Clutch Pressure Control (Linear) Solenoid A in the Miscellaneous Test Menu, and test A/T clutch pressure control solenoid valve A with the HDS.

Does the HDS indicate NORMAL?

YES—Go to step 4.

NO—Go to step 6.

4. Choose Clutch Pressure Control Solenoid Control in the Miscellaneous Test Menu, and command A/T clutch pressure control solenoid valve A at 1.0 A with the HDS.

5. Monitor the OBD STATUS for P0962 in the DTCs/ Freeze Data in A/T Mode Menu for a pass/fail.

Does the HDS indicate FAILED?

YES—Go to step 6.

NO—Intermittent failure, the system is OK at this time. Check for poor connections and loose terminals at A/T clutch pressure control solenoid valve A and the PCM. If the HDS indicates NOT COMPLETED, return to step 3 and recheck.

6. Turn the ignition switch OFF.
7. Disconnect the A/T clutch pressure control solenoid valve A connector.
8. Measure the resistance between A/T clutch pressure control solenoid valve A connector terminals No. 1 and No. 2.

A/T CLUTCH PRESSURE CONTROL SOLENOID VALVE A CONNECTOR

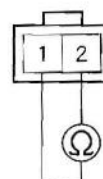

Terminal side of male terminals

Is there 3–10 Ω?

YES—Go to step 9.

NO—Replace A/T clutch pressure control solenoid valve A (see page 14-227), then go to step 16.

9. Check for continuity between A/T clutch pressure control solenoid valve A connector terminal No. 2 and body ground.

A/T CLUTCH PRESSURE CONTROL SOLENOID VALVE A CONNECTOR

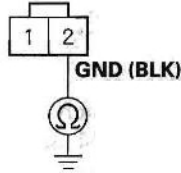

Wire side of female terminals

Is there continuity?

YES—Go to step 10.

NO—Repair open in the wire between A/T clutch pressure control solenoid valve A and ground (G101), or repair poor ground (G101), then go to step 16.

10. Turn the ignition switch ON (II).
11. Measure the voltage between A/T clutch pressure control solenoid valve A connector terminals No. 1 and No. 2.

A/T CLUTCH PRESSURE CONTROL SOLENOID VALVE A CONNECTOR

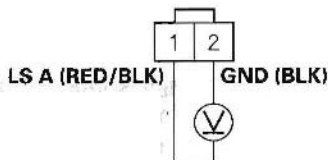

Wire side of female terminals

Is there voltage?

YES—Go to step 12.

NO—Repair open or short in the wire between PCM connector terminal B44 and A/T clutch pressure control solenoid valve A, then go to step 16.

12. Update the A/T software in the PCM if it does not have the latest software (see page 14-9), or substitute a known-good PCM (see page 14-10).
13. Test-drive the vehicle for several minutes in the D position through all five gears.
14. Check for DTC(s) in the DTCs/Freeze Data in A/T Mode Menu with the HDS.

Is DTC P0962 indicated?

YES—If the PCM was updated, substitute a known-good PCM (see page 14-10), then recheck. If the PCM was substituted, go to step 1.

NO—Go to step 15.

15. Monitor the OBD STATUS for P0962 in the DTCs/Freeze Data in A/T Mode Menu for a pass/fail.

Does the HDS indicate PASSED?

YES—If the PCM was updated, troubleshooting is complete. If the PCM was substituted, replace the original PCM (see page 11-219). If any other DTCs were indicated on step 14, go to the indicated DTC's troubleshooting. ■

NO—If the HDS indicates FAILED, check for poor connections and loose terminals at A/T clutch pressure control solenoid valve A and the PCM. If the PCM was updated, substitute a known-good PCM (see page 14-10), then recheck. If the PCM was substituted, go to step 1. If the HDS indicates NOT COMPLETED, return to step 13 and recheck.

16. Clear the DTC with the HDS.
17. Test-drive the vehicle for several minutes in the D position through all five gears.
18. Check for DTC(s) in the DTCs/Freeze Data in A/T Mode Menu with the HDS.

Is DTC P0962 indicated?

YES—Check for poor connections and loose terminals at A/T clutch pressure control solenoid valve A and the PCM, then go to step 1.

NO—Go to step 19.

19. Monitor the OBD STATUS for P0962 in the DTCs/Freeze Data in A/T Mode Menu for a pass/fail.

Does the HDS indicate PASSED?

YES—Troubleshooting is complete. If any other DTCs were indicated on step 18, go to the indicated DTC's troubleshooting. ■

NO—If the HDS indicates FAILED, check for poor connections and loose terminals at A/T clutch pressure control solenoid valve A and the PCM, then go to step 1. If the HDS indicates NOT COMPLETED, return to step 17 and recheck.

DTC P0963: Problem in A/T Clutch Pressure Control Solenoid Valve A

NOTE:

- Before you troubleshoot, record all freeze data and any on-board snapshot, and review General Troubleshooting Information (see page 14-4).
- This code is caused by an electrical circuit problem and cannot be caused by a mechanical problem in the transmission.

1. Clear the DTC with the HDS.
2. Check that DTC P0963 recurs.

Is DTC P0963 indicated?

YES—Go to step 6.

NO—Go to step 3.

3. Choose Clutch Pressure Control (Linear) Solenoid A in the Miscellaneous Test Menu, and test A/T clutch pressure control solenoid valve A with the HDS.

Does the HDS indicate NORMAL?

YES—Go to step 4.

NO—Go to step 6.

4. Choose Clutch Pressure Control Solenoid Control in the Miscellaneous Test Menu, and command A/T clutch pressure control solenoid valve A at 0.2 A with the HDS.

5. Monitor the OBD STATUS for P0963 in the DTCs/ Freeze Data in A/T Mode Menu for a pass/fail.

Does the HDS indicate FAILED?

YES—Go to step 6.

NO—Intermittent failure, the system is OK at this time. Check for poor connections and loose terminals at A/T clutch pressure control solenoid valve A and the PCM. If the HDS indicates NOT COMPLETED, return to step 3 and recheck.

6. Turn the ignition switch OFF.
7. Disconnect the A/T clutch pressure control solenoid valve A connector.
8. Measure the resistance between A/T clutch pressure control solenoid valve A connector terminals No. 1 and No. 2.

A/T CLUTCH PRESSURE CONTROL SOLENOID VALVE A CONNECTOR

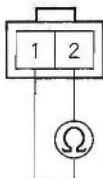

Terminal side of male terminals

Is there 3–10 Ω?

YES—Go to step 9.

NO—Replace A/T clutch pressure control solenoid valve A (see page 14-227), then go to step 14.

9. Check for continuity between A/T clutch pressure control solenoid valve A connector terminal No. 2 and body ground.

A/T CLUTCH PRESSURE CONTROL SOLENOID VALVE A CONNECTOR

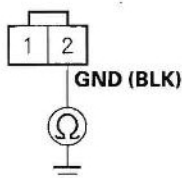

Wire side of female terminals

Is there continuity?

YES—Go to step 10.

NO—Repair open in the wire between A/T clutch pressure control solenoid valve A and ground (G101), or repair poor ground (G101), then go to step 10.

10. Update the A/T software in the PCM if it does not have the latest software (see page 14-9), or substitute a known-good PCM (see page 14-10).
11. Test-drive the vehicle for several minutes in the D position through all five gears.
12. Check for DTC(s) in the DTCs/Freeze Data in A/T Mode Menu with the HDS.

Is DTC P0963 indicated?

YES—If the PCM was updated, substitute a known-good PCM (see page 14-10), then recheck. If the PCM was substituted, go to step 1.

NO—Go to step 13.

13. Monitor the OBD STATUS for P0963 in the DTCs/ Freeze Data in A/T Mode Menu for a pass/fail.

Does the HDS indicate PASSED?

YES—If the PCM was updated, troubleshooting is complete. If the PCM was substituted, replace the original PCM (see page 11-219). If any other DTCs were indicated on step 12, go to the indicated DTC's troubleshooting. ■

NO—If the HDS indicates FAILED, check for poor connections and loose terminals at A/T clutch pressure control solenoid valve A and the PCM. If the PCM was updated, substitute a known-good PCM (see page 14-10), then recheck. If the PCM was substituted, go to step 1. If the HDS indicates NOT COMPLETED, return to step 11 and recheck.

14. Clear the DTC with the HDS.
15. Test-drive the vehicle for several minutes in the D position through all five gears.
16. Check for DTC(s) in the DTCs/Freeze Data in A/T Mode Menu with the HDS.

Is DTC P0963 indicated?

YES—Check for poor connections and loose terminals at A/T clutch pressure control solenoid valve A and the PCM, then go to step 1.

NO—Go to step 17.

17. Monitor the OBD STATUS for P0963 in the DTCs/ Freeze Data in A/T Mode Menu for a pass/fail.

Does the HDS indicate PASSED?

YES—Troubleshooting is complete. If any other DTCs were indicated on step 16, go to the indicated DTC's troubleshooting. ■

NO—If the HDS indicates FAILED, check for poor connections and loose terminals at A/T clutch pressure control solenoid valve A and the PCM, then go to step 1. If the HDS indicates NOT COMPLETED, return to step 15 and recheck.

DTC P1731: Problem in Shift Control System:

- Shift Solenoid Valve E Stuck OFF
- Shift Valve E Stuck
- A/T Clutch Pressure Control Solenoid Valve A Stuck OFF

NOTE: Before you troubleshoot, record all freeze data and any on-board snapshot, and review General Troubleshooting Information (see page 14-4).

1. Warm up the engine to normal operating temperature (the radiator fan comes on).
2. Make sure that the transmission is filled to the proper level, and check for fluid leaks.
3. Drain the ATF (see step 3 on page 14-239) through a strainer. Inspect the strainer for metal debris or excessive clutch material.

Does the strainer have metal debris or excessive clutch material?

YES—Replace the transmission, then go to step 12.

NO—Replace the ATF (see step 5 on page 14-239), then go to step 4.

4. Clear the DTC with the HDS.
5. Test-drive the vehicle in the D position through all five gears at speeds over 12 mph (20 km/h) for more than 20 seconds, then slow down to a stop.
6. Test-drive the vehicle again in the D position through all five gears at speeds over 12 mph (20 km/h) for more than 20 seconds, then slow down to a stop.
7. Monitor the OBD STATUS for P1731 in the DTCs/ Freeze Data in A/T Mode Menu for a pass/fail.

Does the HDS indicate FAILED?

YES—Go to step 8.

NO—Intermittent failure, the system is OK at this time. If the HDS indicates NOT COMPLETED, return to step 5 and recheck.

8. Clear the DTC with the HDS.
9. Choose Shift Solenoid E in the Miscellaneous Test Menu, and check that shift solenoid valve E operates with the HDS.

Is a clicking sound heard?

YES—Go to step 10.

NO—Replace shift solenoid valve E (see page 14-222), then go to step 15.

10. Choose Clutch Pressure Control (Linear) Solenoid A in the Miscellaneous Test Menu, and test A/T clutch pressure control solenoid valve A with the HDS.

Does the HDS indicate NORMAL?

YES—Intermittent failure, the system is OK at this time. ■

NO—Follow the instructions indicated on the HDS by the test result, but if the HDS has not determined the cause of the failure, go to step 11. If any part is replaced, go to step 12.

11. Inspect A/T clutch pressure control solenoid valve A (see page 14-225).

Does A/T clutch pressure control solenoid valve A work properly?

YES—Repair the hydraulic system related with shift valve E, or replace the transmission, then go to step 12.

NO—Replace A/T clutch pressure control solenoid valve A (see page 14-227), then go to step 12.

12. Clear the DTC with the HDS.
13. Test-drive the vehicle in the D position through all five gears at speeds over 12 mph (20 km/h) for more than 20 seconds, then slow down to a stop.
14. Test-drive the vehicle again in the D position through all five gears at speeds over 12 mph (20 km/h) for more than 20 seconds, then slow down to a stop.
15. Monitor the OBD STATUS for P1731 in the DTCs/ Freeze Data in A/T Mode Menu for a pass/fail.

Does the HDS indicate PASSED?

YES—Troubleshooting is complete. ■

NO—If the HDS indicates FAILED, return to step 12 and recheck. If the HDS indicates NOT COMPLETED, return to step 13 and recheck.